

# ZERO BEAT

HAMPDEN COUNTY RADIO ASSOCIATION, INC

NOVEMBER 81

1 QSL BUREAU

SPRINGFIELD, MASS

ARRL AFFILIATED, 34th YEAR

## SPECIAL GUEST SPEAKER

Ed Tilton, W1HDQ, will be our special guest speaker at the November 6, 1981, meeting. Ed, as many of you know, helped to "write the book" on propagation. Licensed since 1933, when he set up his first station on 5 meters in the tower on Wilbraham Mountain, Ed started the VHF column in QST in 1939. He joined the ARRL as full time VHF editor in 1945 and continued in that position until he retired in 1972. Retirement for Ed, however, is not the same as it is for many people. He is still a contributing editor to QST and still actively makes observations of the sun to update the propagation forecasts shown in QST and which are transmitted daily on W1AW.

Ed will reveal some of the mysteries of the propagation forecasts and help unravel the mystique of transmitting our signals through the ether to those remote areas of the world which we would all like to work with our HF and VHF equipment.

This is another in our series of general radio information to be presented this year and one which should not be missed.

## NEW BAND UPDATE

The U. S. Senate has not yet ratified the Final Acts resulting from the WARC Conference last year which provided three new amateur bands at 10, 18 and 24 MHz. The FCC is studying recommendations made for the new bands which includes the ARRL proposal that the 10 MHz. band be open to General class license holders and above, that the band be limited to A1 and F1 modes and that power be limited to 250 watts. If all goes well, privileges could be granted on the 10 MHz band as early as January 1, 1982, with privileges on 18 and 24 MHz granted approximately two years later.

"Quick As A Wink" Printing & Sales Co.  
573 Union Street West Springfield, Ma. 01089

NOTE: NEW ADDRESS

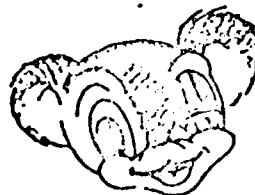

TIDBITS

KC10 likes working cw...WB1HIH listed in the OK-DX contest...A good self teaching text on TV circuits is the Sam's #21630, "Photofact Television Course" for \$8.95...K1BE has a new harmonic, Nicolas John! Jeff also passed First Radiotelephone, FB!...MT Tom ARA raffle- KALCHI won the TS130S; N1BIF the Icom 2AT; N1AGW the scanner; and KALFDE a 2 mtr antenna. Their new Soapstone Mtn repeater is going to be on .00/.60. N1AGV/rpt is now .17/.67!... W1BVR has over SIXTY (!) years as a licensed ham, over 44 as a league official- NE Division Director, ARRL VP, SCM, and Ass't SCM! Percy is a life member of the HCRA, which can only be obtained via service to amateur radio. We're all fortunate to have W1BVR as the Grand OM of Western Mass Section!...KALAPR is experimenting with 6 meter beam element spacing...

\*\*\*\*HCRA TWO METER NET- Monday nights at 8 pm, 144.155 USB\*\*\*\*  
SEE YOU THERE!!!!

CLUB HISTORY- MEMBERS WHO'VE BEEN IN QST:

Does anyone know where Rog is now?

Would love to tell you what he's been up to since leaving the area!

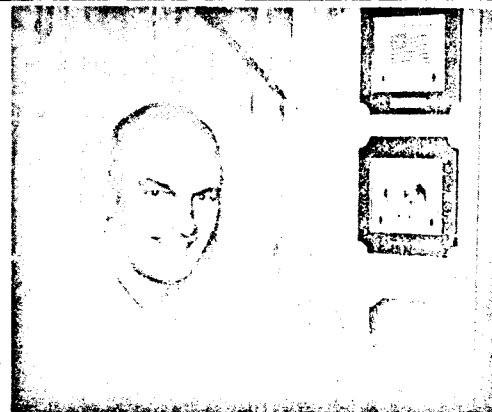

5BWAS Nr. 1

The starting date was Jan. 1, 1970, and W1AX wasted no time working and confirming this brand-new award. In fact, Feb. 4 was the official date of qualification. Here's Rog with his "matched set," 5BWAS Nr. 1 and 5BDXCC Nr. 7. Only two qualifiers to date of both groups, W1AX and W41C - quite an exclusive 5-Band Club! (Photo by John Corey)

CARE AND FEEDING OF THE CDE ROTOR

If choosing a rotor is a problem for you, here are a couple of things you may want to consider.

1. Does the wind load rating of your rotor match the antenna? Remember that if you mount the rotor on a mast (rather than inside your tower) the wind load it can handle will be greatly reduced.
2. Does your system have room to grow? A few more dollars now may save headaches later.

Note, there are no industry standards for calculating wind load that a rotor will withstand, so every manufacturer will probably use different measurements.

Now that you have your new rotor on hand and are ready to install it, first, bench check it. They usually work, but it's tough to fix them at the 100 foot level. Don't short the wires or it may damage the rotor. Belden now has a wire (9405) available that is one gauge larger than what has been used in the past, (costs more too).

When you install the rotor, hopefully with the antenna pointing in the right direction, seal the connections at the rotor, this will save problems later.

When you start using the rotor, have pity on the brake. Let the antenna coast to a stop before you engage the brake. Also, don't park the rotor at the end of rotation. There is a solid stop, which as the antenna rocks, may be broken along with limit switches, etc.

A nice feature of the new CDE rotors is that they are all shipped with a North and South centered scale on the meter. If you want the other scale, just reverse the meter scale plate, and there you are!

The rotors don't require periodic maintenance, but we all know that nothing works forever. If you notice that the rotor is slow in operation, it may be one of two things: The most likely problem would be the motor start capacitor which is located in the control box. If the problem seems to be outside temperature sensitive, the problem could be lubrication. Any good low temperature grease should do.

If you have any problems, you should isolate the problem to the rotor or the control box. All control boxes on all CDE rotors are interchangeable, except a few Ham M's. (Ham II, III, IV, and Tail Twisters are all the same).

You can upgrade a Ham M and Ham II to Ham IV Specs. (7.5 to 15ft<sup>2</sup>) with the following parts: 1. Steel ring gear (51494-10 \$12), 2. Lower brake housing (51453-10 \$14) 3. Brake wedge kit (51464-10 \$12). You may also replace the motor for more torque, but this is not required. Motor (51470-10 \$25).

Upgrading the Ham III to the Ham IV requires only the steel ring gear.

73, Joe, KØTS

## OWNER'S REPORT - KENWOOD TS830S Transceiver

After owning a Kenwood TS520S for two years and experiencing absolute reliability and outstanding performance, I was still longing for a transceiver which had passband tuning. It's a feature in a Drake 2B which I had previously owned and it's one of those things you don't miss if you've never had it and can't do without once you've had it. Careful perusal through advertisements and company specifications, I finally selected the Kenwood TS830S which promised to be an outstanding performer with passband tuning, variable bandwidth, notch filter, selectable AGC constants, and RIT/XIT.

I won't go into specifications and lab test since QST recently tested this model and critiqued it in its product review column. My transceiver was purchased from Adirondack Radio Supply via telephone and plastic money, arriving in two days via U.P.S. After quickly scanning the operator's manual (contrary to standard practice), the rig was fired up and put through its paces. No troubles were found and the packing material and carton were delegated to an inconspicuous space in my already crowded cellar.

It took a while to get used to the digital dial as I found myself unconsciously looking at the analog dial (which tracks well with the digital dial). The digital hold button is a new feature since it permits you to tune away from a specific frequency while keeping that frequency displayed in the digital readout. Great for coming back to the frequency of a DX pileup. The RIT/XIT are neat features and I've used the two of them together to chase DX stations which don't receive and send on the same frequency. By using RIT at the lowest frequency and XIT at its highest frequency, a 5 KHz split can be achieved, thus saving the cost of the outboard VFO.

Passband tuning allows me to copy CW at a 400 Hz pitch rather than the nominal 750 Hz pitch. This is a personal whim which I developed when I owned a Drake 2B. By using passband tuning and variable bandwidth, a desired signal can be put anywhere in the receiver's passband and the amount of selectivity can be adjusted to match band conditions.

By now you've probably noticed that I have not made any mention of any optional CW filters. I haven't found them necessary except maybe two or three times under the worse conditions. With passband tuning, variable bandwidth, notch control, fast or slow AGC, and RF gain manipulation, almost any CW can be received.

Contrary to popular belief, I occasionally operate SSB and find it a pleasure with this rig. Received audio is very clear with a "communications quality". The RF speech processor is quite effective although it takes a little getting used to - one of the things that should be done by the book for the first few times. The noise blanker is also quite effective with operator selectable threshold.

The drivers and finals, 12BY7A and 6146B's, are of normal design requiring tuning and loading adjustments which may be considered a nuisance but which are easy to get used to. Besides, tubes are more forgiving than solid state finals. Power supply design negates 12 VDC operation which is something I had to live without when I selected this rig.

There are many fine radios available but I have chosen this one for its excellent CW capabilities. Most comparable rigs perform equally in SSB service but fall short of what I consider optimum for CW operation.

The preceding are my opinions and observations for a nine month operating period for one of the better value per dollar rigs available.

Gent, WA1CQF

---

FOR SALE

ICOM 255A SYNTHESIZED 2 METER TRANSCEIVER WITH 3AMP  
A.C. SUPPLY \$275.00  
CALL GENT LAM WA1CQF  
413 737 9426

---

FOR SALE

2 METER 7 element beam. T-match, 1.5 - 1 SWR! \$ 5.00  
Jack, WA1YYK 786 2556.

## TEST EQUIPMENT - EL CHEAPO

How many times have you thought about a super delux work bench with an array of neat test equipment? Well, the thought has crossed my mind many times and the idea of paying big money for test equipment (which may probably will be used infrequently) has put a damper on my test gear selections.

The first piece of equipment should be a VOM, (Volt-ohm-milliammeter) which also can be pressed into service around the home and automobile. VOM's come in different price ranges and a fairly decent unit can be purchased for \$ 25 to \$ 50. If you require greater accuracy from an inexpensive unit, it can be calibrated against a more accurate instrument (borrowed from another ham - of course) and a chart can be plotted noting the error.

Another versatile instrument is the venerable grid dip meter. Its uses are widely documented and for its modest investment, it serves as signal generator, wavemeter, and crystal checker. With known capacitors and inductors, it can be easily used to find the values of those unmarked coils and capacitors that you got at the last flea market.

How can you determine the output power of your rig without plunking down \$ 200 for a Bird wattmeter and associated slugs? Scrounge around for a surplus RF ammeter and by using a resistive dummy load, you can determine power<sub>2</sub> output with reasonable accuracy by using the formula  $P=I^2R$ , where I= indicated RF current and R= impedance of your dummy load - nominally 50 ohms.

There are many pieces of equipment that fall under the nice to have category but are not cost effective for most of us to own. Regardless of the type and quality of test equipment you own, get to know how to use them. Dust them off and give them a workout with your functioning gear - lot easier to troubleshoot if you have an idea of what you're supposed to be looking for.

Gent, W1CQF

---

Growing old is simply mind over matter. If you don't mind, it don't matter.

Random Radiation, Pacific Amateur  
Radio Guild.

---

### ANTENNA ANTICS

The virtues of using 300 ohm TV twinlead as a low cost, readily available, low loss transmission line were discussed in our last article. TV twinlead, like open wire transmission lines (ladder lines), is a balanced line and must be fed with either a balanced line tuner or a balun.

Both of these are discussed at great length in the Amateur Radio Handbook published by the ARRL and in other publications dealing with transmission lines and antennas. We will attempt to enhance the theory with practical construction from "junkbox" materials.

The balun is the easier of the two devices to construct and, therefore, we will start with a balun. If you have a tuner that feeds coax, you will only need to connect the balun to your present tuner to use balanced line.

The balun described in this article can easily be made in one evening and uses a ferrite toroid which can be readily obtained from either Amidon Associates or Palomar Engineers, both of whom advertise regularly in QST. Both companies will accept small orders and will provide excellent literature on request. The Amidon toroid which is used in this article is Amidon part number FT 240-61 which sells for approximately \$6.00 plus a \$1.50 handling charge. Specifications for the FT 240-61 are:

O.D. 2.4"; I.D. 1.4"; Hgt .760";  $\mu=125$

The FT 114-61 core can also be used and is approximately one-half the size but is limited to 250 watts.

Both of the above cores are ferrite which has a broader frequency response throughout the H.F. band than does iron powder.

The balun may be wound with a one-to-one ratio, a four-to-one ratio or a nine-to-one ratio. The one-to-one balun will be described in this paper because it exhibits lower losses than do the others. Also, when used in conjunction with an antenna tuner, the tuner provides the impedance match.

Construction is straightforward and does not require any special tools other than wire cutters, sandpaper and a soldering iron.

Start by sanding the sharp edges from the toroid and wrap the core with electrical tape to prevent damage to the insulation on the wire. Cut three pieces of #12 or #14 wire to equal lengths of approximately three feet each. Place the three wires parallel to each other and twist them together. This can be done easily by clamping one end of the wires in a vise and twisting them together with a hand drill or pliers. When the wires are twisted together, wrap them tightly onto the core. At least seven turns are required but the more the better. This is known as a trifilar winding. Space the turns evenly around the core using the entire core. Connect the wire as shown in the diagram,

keeping all leads as short as possible.

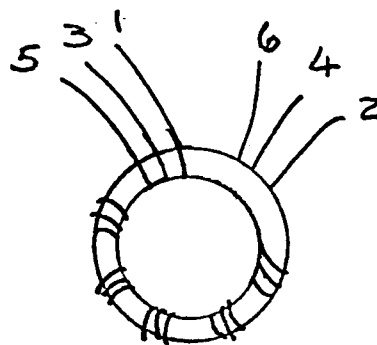
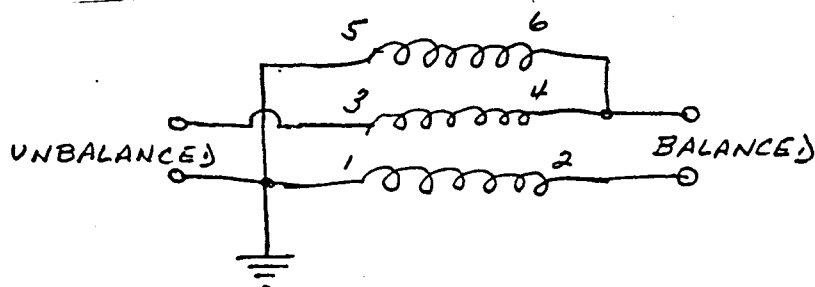

When the windings are completed and connections made, the balun should be mounted either in a weatherproof box for outdoor use or use a simple box for indoor use. The container may be plastic, metal or any other material. Toroids do not need shielding. The mounting will be left to the imagination of the builder. Suggestions for mounting can be found in the chapter on transmission lines in the Radio Amateurs' Handbook published by the ARRL.

This is a very easy project and will save money. If you don't believe it, price baluns and/or coaxial cable.

Our next article will discuss tuners for feeding balanced line from your unbalanced transmitter.

73,

Paul, W1ZKT

Telephone QKT circuit for anyone who might be interested. They are difficult to get right now from the phone company.

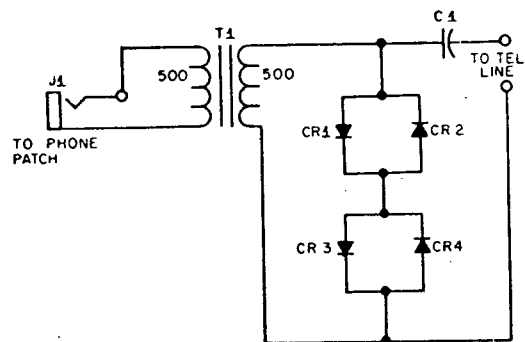

Diagram of the protective coupler for telephone interconnection. C1 is a 2- to 4- $\mu$ F nonpolarized paper capacitor with a working voltage of 200 or more. The diodes, CR1 to CR4, incl., are 100-PRV, 1-A silicons. J1 is a phone connector (panel mount), and T1 is a 500- to 500-ohm miniature transformer (Lafayette AR162).

WHY JOIN A RADIO CLUB?

Today's world is a frightening place- if inflation and taxes don't get you, the neutron bomb might. The impermeance of most things leaves only a few inches of bedrock to stand on. Ask yourself- if the ol' ticker wound down today, how many people outside of the radio club would be there to lay you away? The HCRA needs you, but you need the HCRA even more!

When you first joined the Hampden County Radio Association, I'm sure you wondered how it has survived all these years- no business reports, low dues, voluntary contributions for coffee, - was it serendipity at work? Then after a while you realized how profound the loose structure is- a few announcements, then right into the evening's guest speaker. Stimulated by new ideas, you were movtivated to build that new gizmo.

The ARRL knows the value of strong local clubs. As a member of one of the best, you found out how much the league really does for us. The QSL bureau is a heck of a lot of hard work- and only the tip of the iceberg. Where else could you go to upgrade? Just looking around at the meeting you know these guys are just like you! So with the ARRL manual's, you are motiviated to strive for the amateur extra.

At what better level can the problems of amateur radio be dealt with? The Division Director comes to the club, (when there's something there to eat) and wants to hear your ideas! Your opinion's are as valuable as anyone else in the membership. Besides, your friends want to hear them! Being a member of a radio club can help you realize your ham radio potential and aspirations as nothing else can! Welcome.....

---

ZERO BEAT is soliciting articles from the members. Some suggested topics:



- Construction articles
- Phone patch circuits
- Basic theory
- How to handle traffic
- ATV in Western Mass
- VHF Sweepstakes (for January issue)
- OSCAR
- How you became a radio amateur
- New radio products on the market

We also need associate editors

Many thanks.....

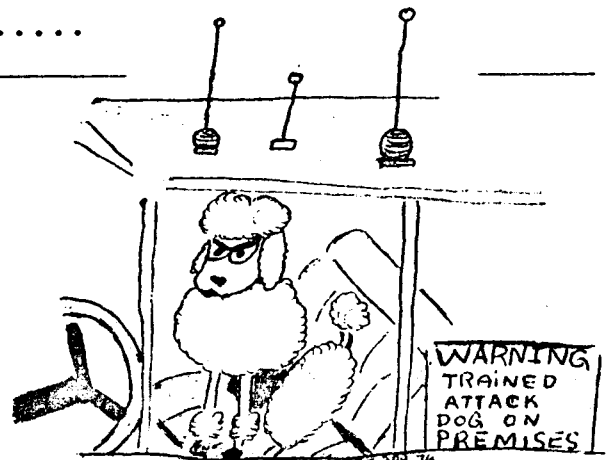



RADIO CLUBS OF WESTERN MASS

Name	Meeting Dates	Location	Club Newsletter	Special Interests	Classes	
					Level	Contact
CENTRAL MASS ARA Worcester, Ma	4th Thurs. (7:30 pm)	CD Hqtrs in Worc. PD	Ham Chatter ed:W1SPG	Field Day, CS(W1BIM) DX-ing, comunity service	N-G	W1SPG
HAMPDEN COUNTY RA Springfield, Ma	1st Friday (7:30 pm)	F.H. Cong. Church, Feeding Hills	Zero Beat KA1CRG	FD, CS (W1NY) VHF SS, QSL Bureau	N-E (Not scheduled right now)	
MT. TOM ARA Springfield, Ma	Varies	WMECO, Brush Hill, W. Spfld	Intermod N1AHW	RPTS: (34/94) (40/00) Community Service	N-G	(WB1EQS)
NORTHERN BERKSHIRE ARC Pittsfield, Ma	Varies	Polish Community Club, Pittsfield	Squelch Tale W1HER	Hamfest, Rptrs (31/91) (52.23-53.23) Community Service		
PROVIN MTN ARC Springfield, Ma	1st Monday (7:30 pm)	Red Cross, Maple st, Spfld.	Echos	RPTS:(10/70), VHF SS, FD Community Service	N-G	WA1VCU

Abbreviations: CS - Club station; FD- Field day; VHF SS- January VHF Sweepstakes; N-Novice, G-General, etc.

COMPLIMENTS OF W1KK, SCM, WESTERN MASS

AC1T 10/82

NOVEMBER ZERO BEAT 1981



HAMPDEN COUNTY RADIO ASSOCIATION, INC.  
RAY MORIN, KALCRG, EDITOR  
97 BROOKHAVEN DR.  
EAST LONGMEADOW, MASS. 01028

HAMPDEN COUNTY RADIO ASSOCIATION, INC.

Calendar for 1981-82

Club Meetings

<u>Date</u>	<u>Topic</u>	<u>Chairman</u>	<u>Speaker</u>
Nov. 6	Propagation	Paul WA1ZKT	Ed Tilton W1HQQ
Dec. 4	Christmas Party	Ron WB1ETS	
Jan. 8	R.F.I.	Malcolm WB1CLO	T.B.A.
Feb. 5	Linear Amps	Dick N8BQU	Gent WA1CQF
Mar. 5	International DX	Steve WA1EYF	BILL Poellnitz K1MM
Apr. 2	VHF, UHF, & Moonbounce	John AC1T	David Olean K1WHS
May 7	Flea Market	Larry K1GXU	
June 4	Banquet	Ron WB1ETS	