

# ZERO BEAT

HAMPDEN COUNTY RADIO ASSOCIATION, INC

W1-QSL BUREAU

SPRINGFIELD, MASS

ARRL AFFILIATED, 35th YEAR

# HAM RADIO AUCTION!

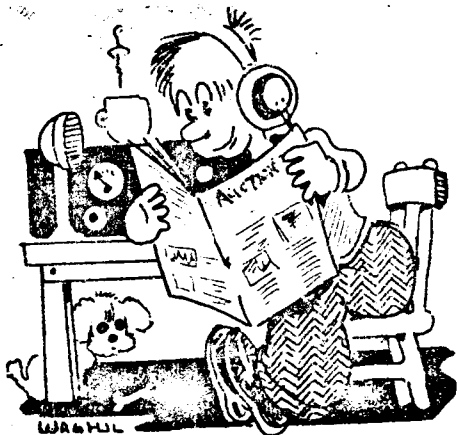

FRIDAY NOVEMBER 5TH, 1982

GRANGER SCHOOL

FEEDING HILLS, MASS

(Diagonally across from the F.H. Cong. Ch.)

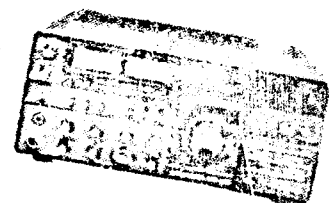

STARTS AT 8 PM

## RULES:

- All items must be clearly labeled with your name or call.
- Club takes 10% of all sales.
- Minimum bids may be marked on items. Seller may bid to protect his own items. No charge if the seller buys his own item. (HOWEVER, we will only try to sell each item ONCE! No one will be allowed to buy and then put the item back into the auction for re-sale.)
- Items donated to the club should clearly be labeled "DONATION". Tax receipts will be available.
- Seller guarantees the item, not the club.



AUCTIONEER HAS FINAL SAY ON ALL SALES. DISPUTED ITEMS WILL BE PUT UP FOR BID ALL OVER AGAIN.

## Editor's Ramblings

Recently there has been much ballyhoo concerning the possibility of a no code amateur license. Well..... let me put in my two cents worth and interject a few comments of my own.

Even though I am diehard cw enthusiast, I wasn't one from the day I was born. I was drawn to amateur radio because of its unique possibilities of communicating with people all over the world from the domain of my own home. Once having decided to become a ham, I set forth to learn the Morse code. Daily sessions with a code practice oscillator and a copy of "Learning The Radiotelegraph Code" carried me into a state where I would mentally transcribe everything I saw into Morse characters. Must have been something for someone to watch me gazing at a billboard muttering strange sounds to myself.

Then came the day to take the Novice test. Sweaty palms and nervousness short of calamity prevailed but somehow the 5 wpm obstacle was overcome. So thereafter began the ritual of novice contacts and coloring in another state on my WAS map. Proficiency and confidence increased and the prospects of the coveted General class ticket beamed in sight. A few months later I was able to change my call from WN1CQF to WA1CQF. Along with vfo, higher power, and phone privileges I finally had the opportunity to "talk" to someone-or should I say "speak" to someone. After a short stint on "fone", it dawned on me that my favorite mode was cw. In essence- I was not born with a love for cw and had to learn it like everyone else. So what is the big deal about a no code license? Are the amateur ranks so desperate that we are willing to compromise the set forth standards to increase our population? Sure there are many highly technically oriented people that we would like to have join our ranks. It seems to me that these people would have the ambition to learn the code and earn their ticket rather than to just have a license handed to them (or are they?). It would be a great disservice to those who have diligently studied, practiced, and probably flunked the cw exam a few times in order to become a radio amateur. Let us maintain the level of excellence associated with being a radio amateur and let those who want to be a ham do it in a way where they can proudly exclaim "I had to learn the Morse Code!".

In an age where technology abounds, cw still maintains the edge over all other forms of radio communications where conditions are marginal. Are we to lessen our capability to perform public service (which justifies our existence in an age where every little bit of the rf spectrum is highly sought after by many other services) and weaken our position to maintain the portions of the rf spectrum allotted to us? The implications of losing rf transmitting privileges are frightening if we don't do some self policing. No code could eventually mean no radio!

Note: The March guest speaker is speaking on this subject.

## SATELLITE TELEVISION

### Part II

TVRO (Television Receive-Only) technology has made giant strides. Many diverse ideas and hardware are being marketed to pick up satellite television. The biggest problem with do-it-yourself projects is the microwave frequencies the birds operate on. 3.7 to 4.2 Ghz is not normally covered in novice classes! The components are hard to find, expensive, and easily go belly-up when approached with a soldering iron. So what do low budget hams do?

Easy! (Somewhat!) Convert it to frequencies we can deal with. Figure 1 shows a basic TVRO downconverter/receiver. 70Mhz is normally chosen as the baseband throughout the industry. Dual conversion is best, but more expensive. Surplus goodies that use single conversion work because the vertical and horizontal signal polarization, with filtering, helps to cancel out the image frequency. (See Fig. 2) In the next article I'll discuss cheap and dirty ways to make single conversion work. Right now, let's look at a basic TVRO installation:

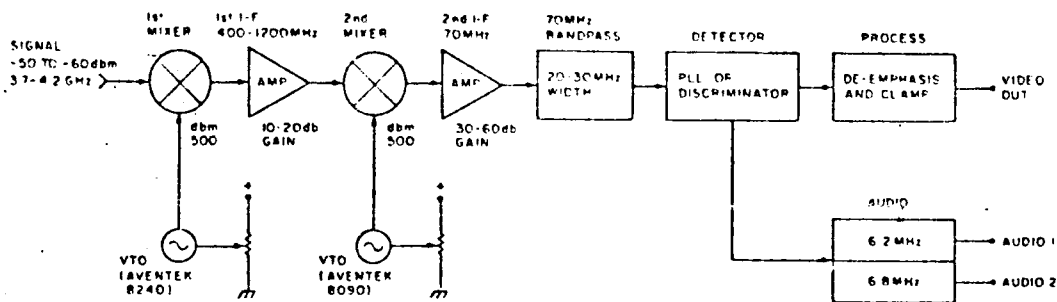

Fig. 1. Dual-conversion design. The first VTO mixes with the downlink signal into the first i-f amplifier. The second VTO is fixed. Gain distribution may vary in different designs. The 70-MHz bandpass filter must be flat in the passband for best results.

### SATELLITE TV HAM NET!

Tune in Sundays at 1800 GMT on 14.311 MHz for the Satellite TV Net. Lindsey Riddle W5JG in New Orleans is Net Control. Then Ken Rae WB0POP takes the reins at 1900 GMT. You'll be amazed at what you can learn in just an hour or so.

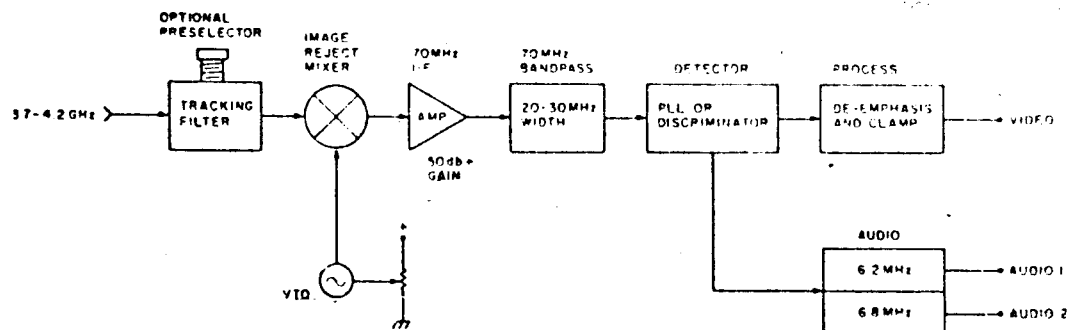
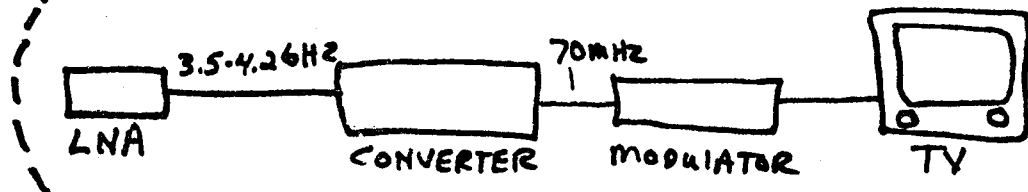

Fig. 2 Single-conversion design.

All TVRO systems basically consist of a high-gain, low-noise amplifier, (LNA), placed at the focal point of a 10-16 foot parabolic dish aimed at a specific satellite. The signals are fed indoors via hardline to a converter unit. This puts out a 70 Mhz i-f frequency, amplifies it, and detects the FM video and 6.2 or 6.8 Mhz audio. These resultant baseband signals then modulate a TV oscillator circuit which feeds your TV's antenna terminals. Various transponders are tuned by varying your channel selector setting.



Just as a point of interest, in the Springfield area, you'd need a 3.65 meter antenna, 100'K LNA, and of course, the earth station. The technology is making rapid strides, and they are now combining the LNA and converter into one box at the antenna, called the LNC.

73, K1BE

---

PATRON SAINT FOR RADIO HAMS?

On October 10, 1982, Maximilian Kolbe was canonized as a saint by Pope John Paul II. Here is truly a saint to adopt as our club patron and for amateur radio's special friend in heaven.

Father Kolbe was a catholic priest, (born 1894, died 1941), licensed as SP3RN in Poland. His first station was installed on December 8th, 1938, at his monastery. Great devotion to our Blessed Mother led him to found a society dedicated to her. (December 8th is a special day for Mary.)

The Nazis invaded Poland in 1939 and sent Father Kolbe to the concentration camp at Amtitz. He finally ended up at Auswitch on May 24, 1941, where he continued to administer to his fellow prisoners in body and spirit.

At Auswitch, if a prisoner escaped, ten men were chosen at random and placed in a "death house", a windowless, airless building, and starved to death. The Nazi commander lined the prisoners up and picked ten. "My wife, my children, spare me!", one man pleaded. The Nazi sneeringly asked if anyone would care to trade places with this Jew-scum? Father Kolbe stepped forward. In that man's place, he helped the nine others through their ordeals and death. Other prisoners could hear them praying and singing hymns. After 15 days the Nazis opened up the building and Father Kolbe was the only one alive. They killed him by injecting poison. (carbolic acid) It was August 14, 1941. His body, like so many others, was cremated.

This man set an example for all of us. Let us adopt him as the HCRA's special patron! To ask that he be named the patron saint of amateur radio, write to- Fr. Michael Jakobek, WØYZH, St. Anne's Church, 200 Hamel Rd., Hamel, MN. 55340. Fr. Jakobek will forward your petitions to the Pope.

## Surplus Revisited

Recently I had the opportunity to acquire a surplus BC221. For those of you that are not familiar with this piece of equipment, it is a heterodyne frequency meter covering 125 khz to 20 mhz in 2 ranges. Also included is crystal calibration oscillator for check points. It can be used at higher frequencies by using harmonics. Even by today's standards, it's a very accurate piece of equipment. Because of its heterodyne design, not only can it output an accurate rf signal but it will beat with an external signal yielding an audio output to headphones.

Since it was designed as a piece of portable (?) equipment, its power source was a battery pack comprised of four  $1\frac{1}{2}$  batteries and three 45 volt batteries for filament and plate supplies respectively. Not wishing to keep Eveready in business, I came up with the following supply to allow operation from ac mains.

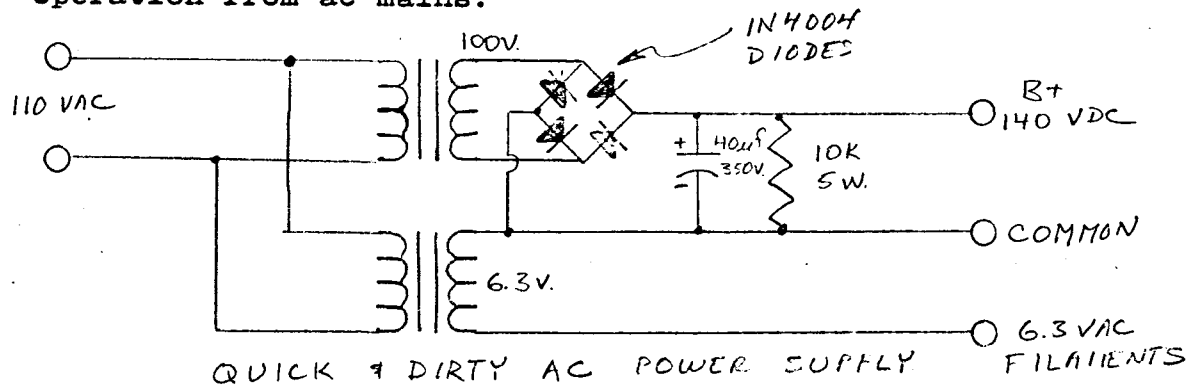

Components are not at all critical. The only criteria being the supply being capable of handling three tubes of the 6SJ7 family. Power requirements are 135 vdc for the plate supply and 6.3v for the filament supply. My circuit uses two separate transformers only because they were what were available in my junk box. There is plenty of room in the battery compartment so parts substitution should not be a problem for the lack of physical space.

For you purists who deem a modulated output is required, a smart smack to the side of the instrument via a open palm should result in an easily identifiable output signal as evidenced by a pronounced "boinggggg" in the output signal.

Considering the modest cost and abundance of these units, it may behoove you to pick one of these gems up and build up a little supply leaving you with a very versatile piece of test equipment which originally cost Uncle Sam a big bundle.

73,  
Gent WA1CQF

## TIDBITS

KALDIP passed technician, FB!...NIAFY works on space suit design, has all the Appollo 8 mission astronaut's autographs, which he resceived personally!...WALYYK busy all summer on the MARS nets...NIPF bought a new car...September BYTE magazine is dedicated to computer uses to help the handicapped...October 12th is the tenative starting date of the HCRA licensing course. Contact WALEYF for info...WLAW is also on 147.555...WALSMH using computer graphics to teach math concepts...KBLY is using a commodore computer, wants to know how to interface it to ham gear...KALJDY is now a club member, welcome...ITT has developed a software programable chip that will enable us to have high resolution TV much sooner. Imagine using it for amateur TV and then switching back to regular or highres TV? Possibilities are endless!!!...WBLETS back in school getting a Master's Degree...

Honorable Barry Goldwater  
United States Senate  
Washington, D.C. 20510

Dear Senator Goldwater:

This refers to your letter of 3 August 1982 jointly signed by Senator Harrison Schmitt. I appreciate the information concerning the Treaty ratification process and your suggestion about immediate action. We have not taken action on the ARRL application for review regarding authorization of the 30-meter band (10.1-10.15 MHz) for the Amateur Radio Service because we were assuming prompt ratification of the Final Acts of the 1979 World Administrative Radio Conference, and we did not intend to initiate the implementation process until after ratification of the Treaty.

In light of your information that the ratification may be delayed and consistent with your view that immediate interim access to the 30-meter band by United States amateurs would be appropriate, I have instructed the staff to revise our approach. Accordingly, in early fall, I anticipate Commission consideration of two related matters. The first will be a Notice of Proposed Rulemaking proposing the implementation of the Final Acts. The second matter will be whether the Commission should authorize early temporary access to the 30-meter band by amateurs, under Section 115 of the Radio Regulations as you suggest. If the Commission were to act affirmatively on both matters, ARRL's concerns would be satisfied.

I appreciate your apprising me of your interest in this matter and I fully support early access by United States amateurs to the 30-meter band. The Commission is anxious to begin the implementation of the Final Acts and I look forward to **ratification of the Treaty at the earliest possible date.**

Sincerely,  
Mark S. Fowler  
Chairman, FCC

Tks  
World Radio

*"Quick As A Wink" Printing & Sales Co.*  
573 Union Street West Springfield, Ma. 01089

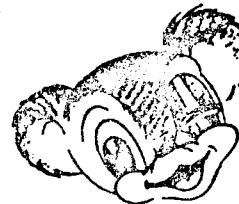

For Sale

Keyboard by the Keyboard Company, great for Visicalc users! For an Apple II or II+, as new \$100.00 I also have an Atari Joystick and about \$200.00 worth of programs on Casette for a TRS-80 model III. Sell all for \$50.00 Jeff Duquette, PO Box 346, Southwick, Mass. 413-569-6739

## HOME BREW

For those of you who are interested in building, we suggest that you look into a company called Circuit Board Specialists. They provide circuit boards and parts for the projects which appear in QST and other publications. Circuit Board Specialists provide some or all of the parts, depending on your junkbox and ability to "scrounge". A partial listing appears below. For a flyer listing many of the available projects you can write to:

Circuit Board Specialists  
PO Box 969  
Pueblo, Colorado 81002

### BASIC RADIO

**UNIVERSAL SERIES  
OCT 1979 thru JULY 1980**

We highly recommend this comprehensive series of amateur radio projects to all newcomers to the art of home construction.

We have kits of parts just as the projects appeared in QST. We are very proud to have been chosen by the ARRL to supply these boards and kits.

You are encouraged to scrounge any and all parts that you can. Rest assured that any parts you cannot find, we do have them. We can offer club and training discounts to schools and for club projects.

<b>UNIVERSAL BOARD-Sept 79 QST</b>	
Circuit Board	\$3.00
Circuit Board (Set of 4)	\$10.00
<b>RF SNIFFER-Oct 79 QST</b>	
Complete Kit	\$25.00
<b>UNIVERSAL POWER SUPPLY-Nov 79 QST</b>	
Complete Kit	\$35.00
<b>UNIVERSAL TRANSMITTER-Dec 79 QST</b>	
Complete Kit (less Crystal)	\$20.00
Set of Kits for all Three Bands	\$50.00
<b>UNIVERSAL VFO 3 Band-Jan 80 QST</b>	
Complete Kit	\$52.50
<b>UNIVERSAL TRANSMATCH-Feb 80 QST</b>	
Complete Kit	\$26.50
<b>UNIVERSAL REC. IF Section-Mar 80 QST</b>	
Complete Kit	\$60.00
<b>UNIVERSAL REC. Converters-Apr 80 QST</b>	
Complete Kit (less Crystals)	\$20.00
<b>UNIVERSAL KEYSER-May 80 QST</b>	
Complete Kit	\$28.50
<b>UNIVERSAL TEST SET-June 80 QST</b>	
Complete Kit	\$30.00
<b>UNIVERSAL IMUS CONT.-July 80 QST</b>	
Complete Kit	\$25.60
Additional Parts, Receiver Modification	\$2.35

In the event that there are parts that you can't get by scrounging, then we can supply them to you.

It has been the objective of the authors of this series to make it not only educational for the beginners, but also as a refresher course for the Hamis who have forgotten the joys of home construction.

### HF RECEIVERS

#### **PROGRESSIVE REC.-Nov 81 QST**

Write for full pricing on this excellent receiver.

#### **MEDIUM GRADE REC.-81 Handbook**

Circuit Board IF Section \$12.50  
Kit of Parts (less Filter FL1) \$125.00

Note: Above kit includes a finished front panel.

Circuit Board Converters \$8.75  
Kit of Parts (less Crystals) \$50.00

#### **20 METER DC RECEIVER-Apr 79 QST**

Circuit Board \$4.50  
Complete Kit (Including Case Parts) \$52.00

#### **MINI MIZER DREAM REC.-Sept 76 QST**

Circuit Board (Receiver) \$7.50  
Kit of Parts (less Crystals) \$70.00

Circuit Board (Converter) \$3.50  
Kit of Parts (less Crystals) \$13.50

#### **YY SPECIAL-Jan 79 QST & 81 H.B.**

Circuit Board \$8.50  
Kit of Parts (Including Case) \$52.00  
Please Specify 40 or 80 Meter Model

### MINIATURE TRANSCEIVER

Complete Kit \$90.00

This is a version of the little transceiver published by QST Aug 80 by Roy Lewellen. We have developed a circuit board for this transceiver and have included a keyer in the circuit. The kit includes, Circuit Board, all Parts and Materials to construct the case just like the one shown on the cover in full color.

### HF RECEIVER ACCESSORIES

#### **CW FILTER ENHANCER-Apr 82 QST**

Circuit Board \$6.50  
Kit of Parts \$38.25

#### **HANDY AUDIO AMP-Dec 79 QST**

Circuit Board \$4.50  
Complete Kit of Parts \$12.00

#### **RC ACTIVE FILTER-Oct 81 QST**

Circuit Board \$4.50  
Complete Kit of Parts \$17.50

#### **9 MHZ SSB GENERATOR-80 & 81 H.B.**

Circuit Board \$7.50  
Kit of Parts (less Filter) \$30.00

### HF TRANSMITTERS

#### **QRP TRANSMITTER-Sept 81 QST**

Circuit Board \$3.75  
Kit of parts (less Crystal) \$20.00

Note: Specify desired band. This little transmitter is recommended to replace previous transmitters such as the TUNA FISH II and the SARDINE SENDER.

#### **TITAN AMPLIFIER-Jun 77 QST**

Circuit Board \$7.00

#### **20-40 METER TRANS.-May-Aug 78 QST**

15 Watt transmitter. Write for pricing.

#### **20 METER TRANS. (6 Watt)-Dec 78 QST**

Circuit Board \$4.75  
Kit of Parts (less Crystal) \$52.00

#### **GOOBER WHISTLE-Jan 76 QST**

Circuit Boards (2) \$8.50

### HF TRANSMITTER ACCESSORIES

#### **VOX IN A BOX-Mar 76 QST**

Circuit Board \$4.00

#### **BOOTS FOR HW-8-Apr 79 QST**

Circuit Board (Filter) \$3.50  
Complete Kit of Parts \$23.70  
Circuit Board (Amplifier) \$4.00  
Complete Kit of Parts \$41.70

#### **NONLINEAR AMPLIFIER-Feb 81 QST**

Circuit Board \$7.50  
Complete Kit of Parts \$35.00

### KEYERS

#### **EL CHEEPO KEYSER**

Circuit Board (with Instructions) \$6.50  
Complete Kit of Parts \$18.00

#### **MORSE KEYBOARD-81 Handbook**

Circuit Boards (3) \$21.50  
Kit of Parts (less Keyboard) \$60.00

#### **MORSE KEYBOARD-Jan 78 QST**

Circuit Board \$8.50  
Kit of Parts (less Keyboard) \$38.75

#### **MEMORY FOR ABOVE K.B.-Dec 80 QST**

Circuit Board \$7.50  
Complete Kit of Parts \$22.25

#### **VERASKEYER-May 79 QST**

Circuit Board \$12.50



### Phone patching

Included under the definition of third-party traffic is the phone patch. You won't find much on this subject in anything from ARRL, particularly in what comes from the Communications Department. Until about 1970, ARRL completely ignored the topic and replied to anyone who asked that phone patching was illegal. But it was being done, and had been done ever since amateurs began to use voice. The ARRL knew about it, the FCC knew about it, the telephone people knew about it, but it wasn't causing anybody any trouble, wasn't costing the phone company any revenue, and in many cases it was a significant public service.

Then a decade ago, a manufacturer of commercial two-way radio gear offered an accessory to allow commercial users to patch a phone line into their radios, making it possible, for instance, for an ambulance driver to talk directly to a doctor via phone patch instead of having the base-station operator repeat everything from one circuit to the other. A telephone company filed suit asking for an injunction, because such a device was illegal, contrary to the phone company's tariffs. The judge refused to grant the injunction until he could ask the FCC about it, because the defendant claimed that the phone company's tariffs were too restrictive. The FCC agreed, and started rule-making proceedings to regulate private devices to be connected to the public phone system.

QST has carried several articles since that date telling how to do it, what the rules are, and some of their publications discuss it too. But there has been no effort whatsoever to organize it, nor any attempt to set up a National Phone Patch System like the National Traffic System. About all you hear from the ARRL Communications Department is an occasional warning to keep it legal. Organization has come from elsewhere.

### Independent nets

While some patches are arranged through the National Traffic System (NTS) by an exchange of formal messages between stations, or even by contacts made on those nets that don't have a policy of not permitting it, most of the organized patch activity takes place on the independent nets, and probably more on 20 meters than on any other high-frequency band. You can find a net in session nearly any time of day on 14.313 kHz, for example, that can arrange a

patch for you. This frequency has become Amateur Radio's maritime calling frequency, where persons at sea make contact with the folks back home, but the amateurs there are happy to facilitate a patch for anyone.

VHF patching is governed by the same rules, but is otherwise quite different. It deals mainly with local calls and is usually controlled by the operator making the call (autopatch), normally from a mobile station, with no need for the base station (usually a repeater) operator to take any action. This discussion concerns HF patching.

### Public service

Nobody objected to amateur phone patches, primarily because they provided a valuable public service. They still do. Explorers in the Antarctic, military personnel everywhere, missionaries in the Amazon jungle, merchant seamen away from their families for months at a time, and many others have found Amateur Radio's services a great boost to morale, and in many cases actually a means of saving lives. A baby's cry may be a nuisance to many people, but to a young father snowed in at McMurdo it can be the sweetest of music. And a doctor at a remote outpost often would be unable to help a dying patient without Amateur Radio's facilities making it possible to consult specialists or obtain special drugs.

Phone patching has some problems in common with handling formal traffic, some that are peculiar to itself. One problem the two have in common is really a mutual problem: the lack of liaison, in many cases, between the two. It often happens that someone seeks a patch when a formal message via NTS would be just as effective, much easier, and more economical of spectrum. And there are times when formal traffic is too slow or when two-way conversation is really needed to discuss something. There have been some efforts to have stations which specialize in handling formal traffic, check into the phone patch nets on a regular basis, but they usually find the pickings rather slim.

Another common problem occurs when one tries to explain to the non-amateur recipient of the message or the "patchee" that everything is quite legal, there is no hidden charge involved, that this is not a crank call, nor is it a prank. In addition, the patch operator has to instruct the non-amateur on proper procedure, regulate the signal levels to transmitter and phone line (turn the receiver audio down to make the person at the other end speak louder), monitor to be sure that no illegal transmissions occur, perhaps adjust the rig to compensate for frequency drift, and in many cases switch between transmit and receiver. Both formal traffic handlers and phone patchers must keep records of the traffic. Formal traffic handlers usually do this by retaining a

copy of the message in the file. Phone patchers may record the names of the persons being patched and a description of what was discussed or they may make a recording and keep that on file.

There may well be more amateurs who are equipped to make phone patches than there are amateurs who handle formal traffic on any kind of regular basis. And there are some who rival the regulars of the Brass Pounders League in the time spent and the numbers of patches made during a typical month.

Senator Barry Goldwater's club station K7UGA does an enormous volume of patching — some 50,000 during the Vietnam War, for example. And I received letters recently from Jerry Swank, W8HXR, who specialized in handling traffic for Antarctica, with 10,000 contacts and 25,000 hours operation to his credit. To put that figure in perspective, remember that there are slightly under 8,766 hours in a year, and Jerry presumably had to eat, sleep and earn his living as well. The work of Jerry and many others like him has its reward, however, in the appreciation of the people it helps.

Finn Ronne, for example, in his book *Antarctic Command*, tells of his experience commanding Ellsworth Station during the 1954 International Geophysical Year, and has much to say about the problems and difficulties they faced, often life-endangering, because of bureaucratic foul-ups, incompetence, injured egos, and other weaknesses — and at times maliciousness of human nature. But one aspect of his expedition received nothing but praise, and that was the support he and his men received from Amateur Radio.

### Words from an expert

As my experience with phone patching is quite limited, I've decided instead to let Jerry do the talking on this subject, giving some excerpts from his two letters.

Jerry says he prefers to switch manually. If the local party stops talking long enough for the VOX to drop out and the radio noise comes on the line suddenly, it can be upsetting. Furthermore, the station at the other end will be using push-to-talk if it's a military unit. "Did you ever try running a patch in noisy conditions with one station running PTT and the local running VOX?" Jerry asks.

Guidelines for the operator: Jerry says, "Probably the most annoying is the habit hams have of joining the conversation." Shut up and let them do the talking. Especially if you're using a long-distance line that they are paying for by the minute, don't make them pay for listening to you gab. We're offering them a communication service. What they would like most of all is to be together by themselves, but since that's impossible,



# Traffic

we do the best we can and make our presence as unobtrusive as possible. Incidentally, that's good advice for amateurs who deliver formal traffic too. We are unavoidably involved in other people's private affairs and so should be discreet in what we say.

Next in importance, says Jerry, is not to put your party on the air until the conversation actually begins. Don't broadcast the dial tone, exchange with telephone operator, or your conversation with the person you're patching. It serves no useful purpose, and sometimes can do serious harm. And it's illegal — unnecessary transmissions. Sometimes, too, it's possible for the other station to clear other traffic while you're arranging your patch.

Jerry says he never explains anything to the telephone operator; it only confuses things. He just says, "Station to station collect. Tell them Joe is calling." When the party answers, the operator will say, "I have a collect call for anyone from Joe. Will you accept the charges?" And of course there is an enthusiastic answer, "Absolutely!" He then says, "This is Jerry in Ohio and I have Joe on the line. He will talk first, and when he says 'over' it is your turn to talk."

If conditions get too bad, he says he will try again another time. After the patch is the time to explain how it is done — if the party is interested — and perhaps add other details, but not on the air. As Jerry has specialized in Antarctic patches, he can answer many questions that may occur to the folks back home. But again, do it only if the party wishes.

While ARRL has no organized phone patch activity, MARS does. Lately, even places where military personnel used to send their patch traffic on the amateur bands — such as Antarctica — are now turning to MARS circuits, perhaps because of the increasing congestion on the amateur bands, and perhaps also because of the immature individuals who derive some kind of morbid pleasure from disrupting patches.

Jerry had his battles over the legality question too. He asked the FCC in Washington, and was told the FCC has no jurisdiction. "We assign frequencies to the Navy and they do as they please with them. What they do in Antarctica is their own business."

He asked the nearby monitoring station in Chillicothe, Ohio. They said they were quite aware that he was running the patches. He said sometimes he didn't break for ID in the middle of a patch even though it might run for an hour. They replied, "No, we would never cite you for that. You are performing a good service. The rule is 'as soon as possible.' You do that."

One of the ex-"Pole Cats" later went to Greece, and Jerry kept a schedule with him on 15 meters. His mother — Carolyn Smith, WB6UVU — often couldn't hear him, so he made tape recordings from one and played it to the other. He asked the FCC about that and was told it was OK since all three were licensed amateurs.

Then he told all that to an ARRL director at a meeting and was told it was illegal. "But the FCC says it's OK." Jerry was told, "Don't take those guys' word for it. They don't know what they are doing. I would go by what the ARRL says." Strange! But then he was only one individual even though a member of the Board of Directors; he was not the ARRL.

## Lincompex

A speech-processing technique that has been around nearly 20 years offers much improvement in voice communication, and would be particularly useful in phone patch work, but I've never seen it even mentioned in any amateur publications. The sideband signal is completely compressed, so that loud and soft sounds have the same amplitude. The audio input is rectified at the same time, giving a DC voltage varying with the amplitude of the modulating signal. This voltage is used to frequency-modulate a carrier at about 2800 Hz, shifting 2 Hz for each decibel change in audio level. The audio itself is passed through a low-pass filter, cutting off around 2500 Hz.

The receiver's processor includes a variable-gain amplifier which restores the amplitude variations as recovered from the 2800 Hz FM carrier. As a result, the weaker components of the voice signal are protected from being swamped by noise, and the improvement in intelligibility is found to be 10dB or more, often giving wire-line quality to what would otherwise be marginal. The system was developed by the Bell Telephone Laboratories and the British Post Office. It would probably require special temporary authorization from the FCC for amateurs to use it, but such experimentation is explicitly encouraged by the FCC and so authorization should not be hard to obtain. And if the system became at all popular, the FCC would soon authorize it on a regular basis.

H.F. Communications in Frederick, Maryland manufactures Lincompex processors, as do others, but the price is out of the reach of most of us. Those interested who wish to go the homebrew route will find useful information in a QST article by John E. Kaufmann, WA1CQW and Gary E. Kopec, WA8BNU — "Homomorphic Speech Pro-

cessor," March 1976, page 33. This is not a complete Lincompex (linked-compressor-expander) unit, but rather an audio compressor that uses similar principles; it reduces but does not eliminate completely the amplitude variations of human speech. But the circuits could be adapted easily, with the addition of the frequency-modulated sub-carrier.

One final consideration to bear in mind, however, is that most amateur transmitters would have to be operated at much lower power levels when using Lincompex, because the transmitter operates at a 100 percent duty cycle, full power continuously, as when transmitting RTTY. □

TN X! WORLDRADIO

## She's not handicapped with Amateur Radio

Gayle Sabonaitis, WA1OPN cannot see, cannot hear and cannot walk. She has been blind since she was 1 year old, deaf since 15, and an incurable nervous disorder has destroyed her equilibrium so she must crawl up and down stairs and get about in a wheelchair.

Gayle Sabonaitis recently earned an amateur Extra Class license. The 38-year-old Worcester, Massachusetts, VA, also holds a full-time job.

According to an Associated Press story that appeared in the New York Daily News, Gayle earned her Novice license 11 years ago. Because she cannot hear, she copies code by touch. A piece of plastic the size of half a ping-pong ball is glued to a speaker cone. Gayle places her hand on the ball and reads the incoming code by feeling the vibrations.

"When she's using Morse code, she's without a handicap," the AP quotes Dr. Peter Sosnow, a 1964 head of the University of Massachusetts Medical Center, as saying. "Any person that in contact with has no conception that she's deaf and blind. She sounds and seems the same as any other person."

The story said Gayle "crawls to a corner of her apartment every night to get on the air to talk with radio friends."

"I hear every word people say with my fingers. I hear through my hands," the AP quoted her as saying.  
— Albany ARA, NY □

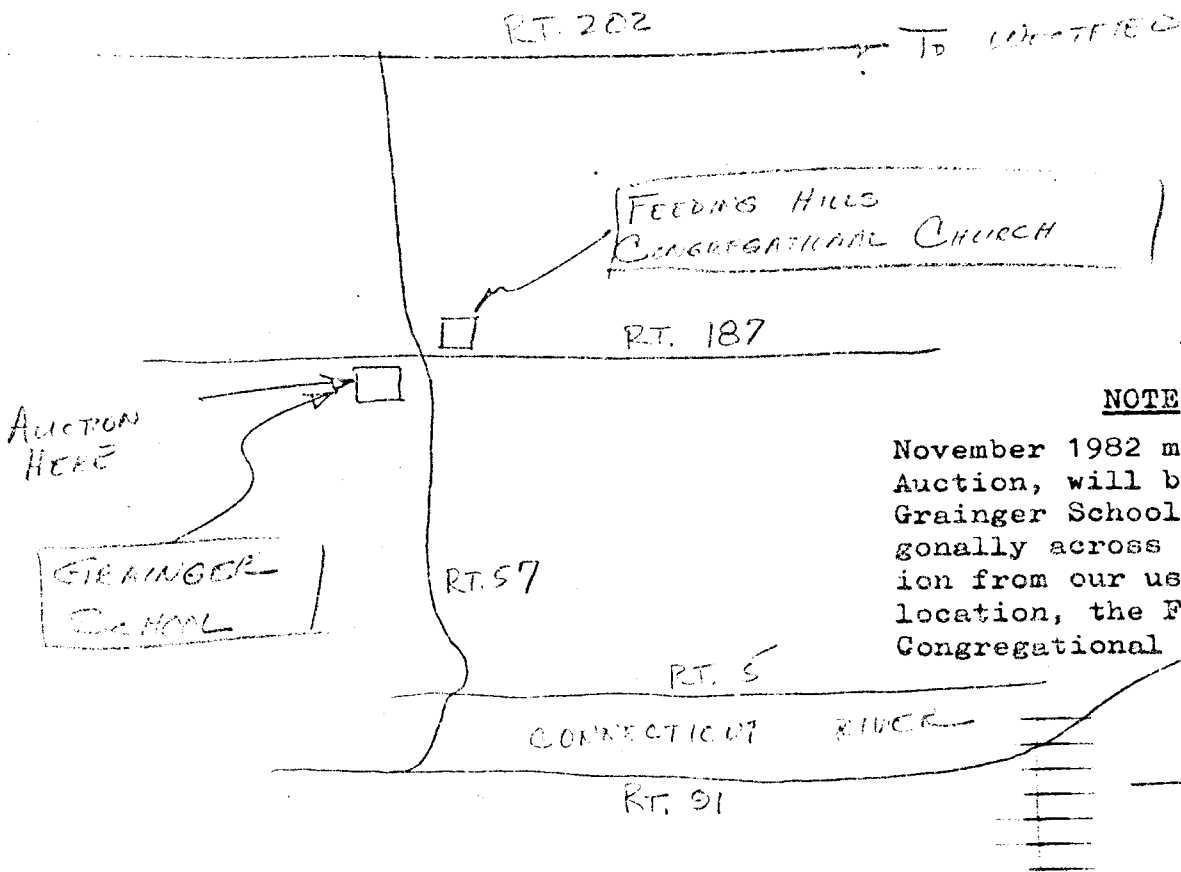

NOTE

November 1982 meeting, Annual Auction, will be held at the Grainger School located diagonally across the intersection from our usual meeting location, the Feeding Hills Congregational Church.

Hampden County Radio Assn.  
 Gent Lam, WA1CQF, Editor  
 38 Porter St.  
 Springfield, Mass. 01104

November 1982 Zero Beat

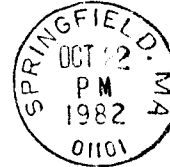

AC1T E Y 10/82