

Dec 78

THE HAMPDEN COUNTY RADIO ASS'N. INC.

SPRINGFIELD, MASSACHUSETTS

DECEMBER ISSUE # 12 1978



JOINT ISSUE WITH MOUNT TOM ARA!

CLUB OFFICERS

President	Larry Soltz	WB1CJH	567-3444
Vice-president	Ron Beauchemin	WB1ETS	593-9852
Secretary	Frandy Johnson	N1FJ	584-9005
Treasurer	Steve Shore	W1LZEV	(203) 243-3030

NEXT MEETING

FRIDAY, DECEMBER 8th

FIRST ANNUAL CHRISTMAS PARTY WITH THE MOUNT TOM ARA AND HAMPDEN COUNTY RA

HOLYOKE ELK'S CLUB

HOLYOKE, MASS

PRESIDENT'S CORNER

I have been told by fellow hams that I should not be concerned with firms selling linears to the CB'ers or two meter rigs to unlicensed individuals. These are "None of our business; Leave these concerns to the FCC." , even though they are ineffective because they lack the manpower. This past weekend I was introduced to the radio world "above channel 40". It was a world of CQ's interspersed with CB jargon. The CQ's were answered by "good buddies" from Ohio, Michigan, California, etc. This activity occurred throughout the space above channel 40 to the lower part of the amateur ten meter band! There were as many pile ups as on 20 meters. "Who needs ham radio?", said the operator. It is critically important for us to write our representatives asking to make it illegal to sell amateur rigs or amplifiers to unlicensed individuals. This is actively being supported by the ARRL. Fellow hams- if we don't all take an active part in policing the frequencies and the privileges our licenses have earned for us, we are going to lose them by default! Report violations directly to the FCC* Write to the ARRL with documentation.

73,

Larry, WB1CJH

*flagrant violations on the ham bands should be reported to:
 Allegan, Michigan FCC enforcement center, (616) 673-2063
 CB violations to this number-(308) 382-4296

DECEMBER ZERO BEAT
Joint MTARA/HCRA

Here are the addresses of various HCRA activities:

ZERO BEAT

c/o J.J. Duquette
P.O. Box 346
Southwick, Mass 01077

Want ads are free for members, articles, comments, activities always solicited.

QSL BUREAU

Hampden County RA
P.O. Box 216
Forest Park Station
Springfield, Mass 01108
Keep envelopes on file for all your calls; queries etc should be sent here.

TREASURER

Steve Shore
20 Valley View Dr.
Bloomfield, Ct 06002
To pay dues or renew.

PRESIDENT

Larry Soltz
69 Hazardville Rd.
Longmeadow, Ma 01006

To volunteer, complain question; General club business.

CLUB STATION

W1NY
c/o Art Zavarella
1700 Main St.
Agawam, Ma. 01001

For our club QSL, s.a.s.e pse!

HCRA "WORKED 25 MEMBERS" AWARD

C. Norman Peacor
Country Club Dr.
Monson, Ma 01057

QSL's not required Send their call, time, freq, and one of your QSL's for collection.

Visiting Your Headquarters

League members (and other interested persons) are always welcome during regular business hours for tours of the ARRL administrative headquarters and the Maxim Memorial Station, W1AW. Visiting hours for both are Monday through Friday from 8 A.M. to 4:30 P.M. [Local Eastern Time]. Large groups should make advance arrangements, one week ahead. Give date, time and number attending. Please call 203-666-1541. W1AW operates until 1 A.M. on weeknights and from 3:30 P.M. to 1 A.M. on Saturdays and Sundays. All facilities will be closed on July 4, September 4, November 23, and December 25.

The full office tour includes a description of the services and operations of the various departments: Communications, Club and Training, Technical, Membership Services, Publications Programs, and Advertising. Highlights of headquarters include the museum, Hiram Percy Maxim's "Old Betsy" spark-gap transmitter (still in working order!), and the Ralph P. Thetreaux Memorial Antenna System. An FCC-licensed amateur may operate the station in between bulletin and code-practice schedules (see "Operating News" in QST) upon presentation of the original of one's current license.

FROM NORTH — BRADLEY FIELD AND WESTERN MASSACHUSETTS

Go south on I-91 through Hartford to exit 28 (sequence is 29A, 29, 27, 28), Wethersfield/Newington, for U.S. 5 and Connecticut 15. Proceed southwest for 3.5 miles and onto the Berlin Turnpike, then exit at Route 175. Turn right from the ramp and head west for one mile over Cedar Mountain to the third traffic signal. Turn right again (north) at Newington center onto Main Street (Route 176). Continue for 1-1/4 miles to League hq.

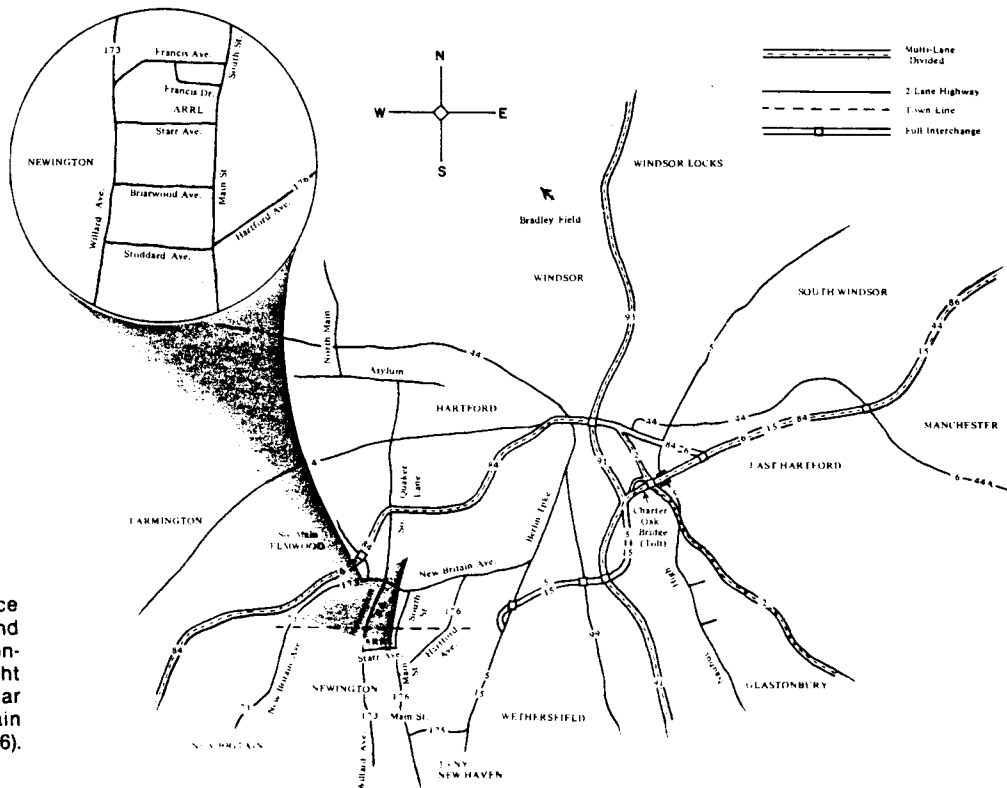



Office of the Section
COMMUNICATIONS MANAGER

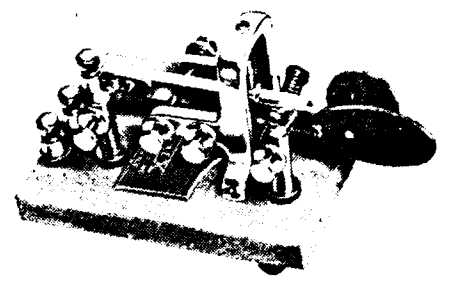

WESTERN MASSACHUSETTS

OPERATION OF THE WESTERN MASS. CW TRAFFIC NET: (Daily at 7 pm,
on 3562. WMN has been in operation since 1932!

CHECKING IN:

When there is a break, call the Net Control Station. (NCS)
He will send your call. i.e. (W1KK) NCS... "QNI, K" ; You- "W1KK de
AC1T" or send something to let him know you're there: "T". NCS-
"AC1T, K" or "T, K". You- "QRU, K" or "W1KK de AC1T, QRU, K"
NCS- "R, AS..."

If you haven't got traffic, send "QRU" and wait for instructions
from him. If you have traffic to send, report it thusly: any for
within our section list by calls or towns. Any going out of WM lump
together as "THRU". i.e. Suppose you have one for CONN, one for
Maine, and two for California. You would say "QTC THRU 4". The NCS
takes it from there. DO NOT LEAVE A NET UNTIL DISMISSED BY THE NCS
or when he sends "QNF" meaning the net is free.

DURING THE NET:

Immediate break-in is desirable but not necessary. Most NCS
have it. So, if you're copying traffic and begin to miss, just hold
your key down for a few seconds; The NCS will probably send a
question mark, (...--..). You then send the last word you received
correctly and he will then resume the message.

In some cases the NCS may call you and a station that has traffic
and say; "U 5" or "D 3". That means five khz up or 3 khz down to
handle the traffic. The receiving station should call first. After
the traffic, you go to the net frequency and just send your call
during a break. The NCS will acknowledge.

EXPLANATION OF REPORT CARD:

Orig.- A message filed at your station by a third party, either in
person, by telephone, or mail. You get one point for accepting
the message.

RECD.- One point for each radiogram received by you via radio.

SENT- One point for each message sent by your station.

DELD.- One point for each message delivered by you, in person, by
mail, or by telephone.

SAMPLE MESSAGE:

NR 1 R W1BVR 7 Lanesboro, Mass Aug 19 (Preamble)
to Joe Blow, 18 Main Street, Podunk, Maine 30341 555-1111 (Address)
-...- WAITING PATIENTLY FOR YOUR QSL X 73 -...- (Message)
Perce W1BVR .-.-.- (Signature)

NR- any number you wish to assign.

R- Routine message; P- Priority; Spell out "Emergency"

7- number of words in text.

X - means "period". Note that "73" is part of the text!

Report your traffic by the fifth of each month to the SCM.

MISCELLANEOUS:

If a net did not take on new members, it would eventually pass out

ZERO BEAT DECEMBER
Joint HCRA/MTARA issue

-of existence. We welcome all newcomers! WE WILL ADJUST SPEED AS NECESSARY. Come on in and have some fun.

If you prefer, (or in addition to) we have two Western Mass

Phone Nets: WMPN Mon- Fri. 4:30 pm 3935

WMEN Sundays, 8:30 am, 3937

These require less skill, but don't develop cw proficiency!

WHO CHECKS INTO THE WMN?

WAIOPN	WIBVR*	WLDWA	N1CQ*	AC1G
K1PUG	W1ZPB	W1NLE*	K1SSH	AC1T*
W1DOY	W1KK*	W1DVW*	W1LAUV*	N1YY*
W1TM*	K1IJV*	N1PF*	K1BE*	*HCRA member

WHO ARE THE USUAL NCS?

Sun- W1TM, Bill	Wed- W1ZPB, Walt
Mon- K1IJV, Jean	Thurs- W1LAUV, Tom
Tues- W1DOY, Larry	Fri- W1KK, Art
	Sat- W1BVR, Perc

"Zero Beat" will send you a free "Q" signal chart for an SASE!
Thanks for article to W1KK and W1BVR, our ex- SCM emeritus!

CALENDER OF EVENTS!

December 8th- HCRA/MTARA Christmas Party.
Dinner, Dancing, Drinks.

January 5th- HCRA meeting on Lasars and Holograms or Amateur Television. K1YQQ is setting it up. AC1T will show a film on the Sweepstakes at W1NY. SS logs will be given out.

January 27th, 28th- VHF Sweepstakes! We are entering this contest as a club in a big way. Plan on getting in on the fun!

February 2nd- "Ham Pilots Night" at the HCRA. FAA films, slides of our own flying members! Plan on bringing in a few of your flying slides to share. N1FJ is the major domo.

March 2nd- ARRL guest speaker on a technical topic. W1PUX is organizing it.

April 6th- Tom McMullen, W1SL from Ham Radio Horizons will speak on bouncing signals off the moon and back to earth. Tom is always popular and brings a few free samples. W1BFIP is setting things up.

May 4th- Our annual flea market. W1BZW and committee getting it set!

June- Our annual HCRA banquet. Election of new officers.

June 23rd, 24th- Field Day!!!

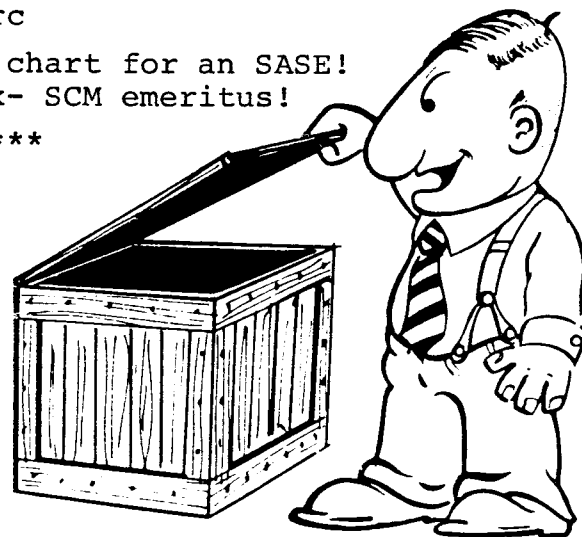

Topics subject to change. A film on K1CC will be shown sometime this year. We are happy to list other club's events, deadline the 15th of preceding month.

ZERO BEAT DECEMBER
 Joint HCRA/MTARA issue

Type	Impedance	Loss in db per 100 feet						
		3.5 mhz	7 mhz	14 mhz	21 mhz	28 mhz	50 mhz	144 mhz
RG-8/U	52 ohms	0.3	0.45	0.66	0.83	0.98	1.35	2.50
RG-58/U	53.5 ohms	0.68	1.0	1.5	1.9	2.2	3.10	5.70
RG-59/U	73.0 ohms	0.64	0.9	1.3	1.6	1.8	2.40	4.20
TV Twin line	300. ohms	0.18	0.28	0.41	0.52	0.6	0.85	1.55

Club Special: New RG8A/U foam-core coax, only 15¢ per foot to HCRA members. Please order in 50' increments. Delivery at January meeting. Frandy Johnson, N1FJ, 413-584-9005.

Note: This is the best coax available. Compare this to the stuff above.

HCRA
 RG-8A/U 52 ohm .25 .36 .53 .67 .80 1.1 2.0
 velocity factor of .81!

CIVIL PREPAREDNESS: Preparations for Region-wide Disasters!

(Last in series of four)

The big snowstorms of January, 1978 may happen again this season. Boston and most of New England's seacoast became paralyzed for a week. States like Connecticut actually closed down! Most of us were warm and cosy, and the brunt of the storm missed us. But would you have been in need of help or able to render assistance if called upon?

Keeping your rig operating could mean life or death for a stranger. You'll need a car battery when the power fails. What would you do for heat? A Coleman stove could provide warmth for the shack and hot food. (Caution: Ventilation is required to prevent asphixia!) Extra blankets, jackets, etc and if you have one, a fireplace blazing away will provide warmth. Invite the neighbors in to provide some cheer and to conserve fuel.

Ella Grasso enlisted the help of four wheel drive vehicles to rescue motorists stranded on Connecticut highways.

Is your two meter rig ready to quickly run off a portable antenna and a cigarette lighter? Are extra nicads ready or are you planning to visit the local electronics store during a blizzard?

Are you in the ARES? Familiar with net procedures? The time is NOW to get ready!

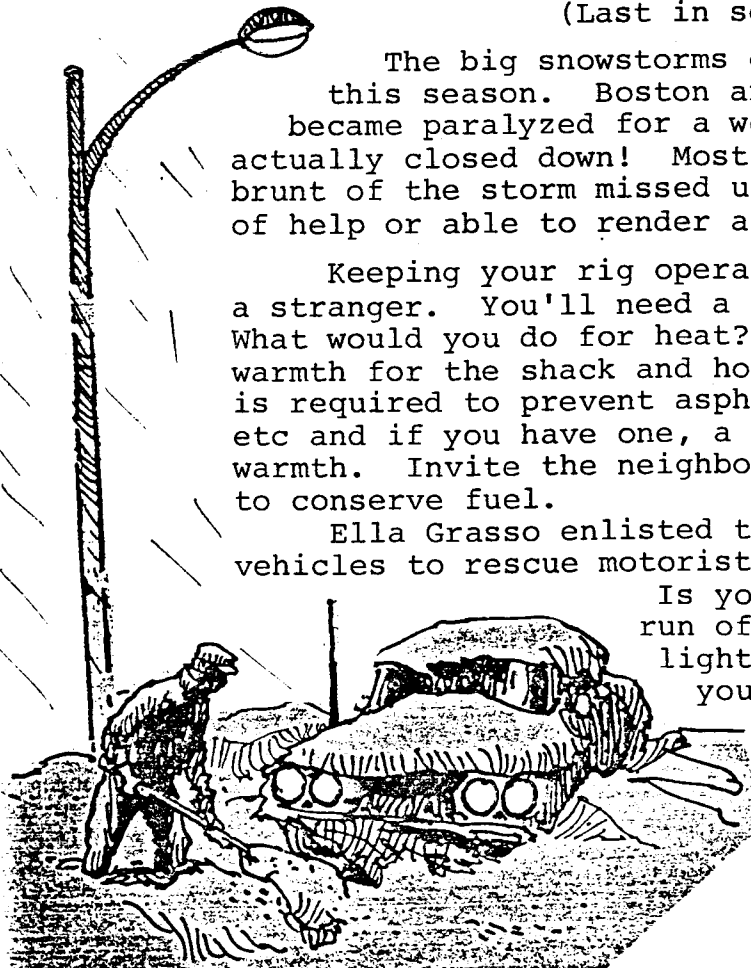

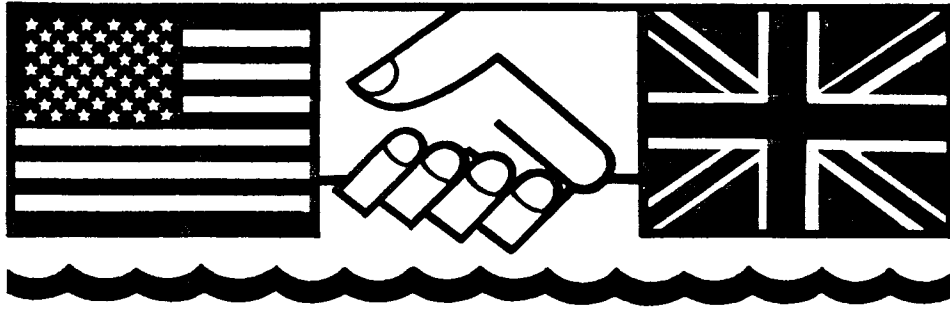

The harsh, sweet sound of a spark gap transmitter; who remembers it best? The mini-reunion of KMLCC operators at Boxboro sure do! Whittey, KLVV, was glad to see the large group the HCRA sent to the Cape. Anecdotes were swapped. He's going to lend us a two hour film and slides with tape from the Marconi Memorial Station. We are not sure when it will be shown. However, we'd like to copy the slides to keep one set for the club and donate one to the ARRL library. This is an important piece of ham history! Unfortunately the club is on a tight budget and the HCRA has no money for this project. If you'd like to help, send a donation to JJ Duquette, P.O. Box 346, Southwick, Mass 01077. Another piece of history was saved by

Jeff when he bought a silent key's complete circa 1910 ham station. This spark gap transmitter and crystal receiver (tunes 100 to 300 meters!) will be made to work, (hopefully!) and demonstrated the night we show the Marconi film. Too bad it can't be used in the "Nostalgia Exchange", we'd win for sure!

The Marconi Transmitter

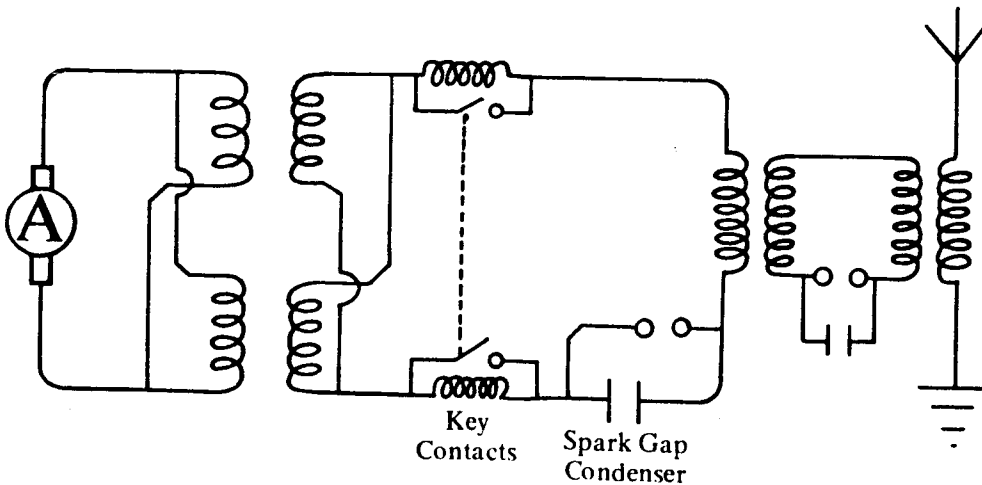

JOTTINGS!

WB1CLO passed his advanced, congratulations, Malcolm...K1CYG still has some goodies for sale, call Stan at 786-4047...Reciprocal Canadian license forms are available for an SASE to ZB...Listen to WHYN, 56 AM or 34/94 Mt. Tom for cancellation notices of HCRA meetings during storms... January Zero Beat will have our usual columns like "Miscellaneous Notes, New Members, etc. We'll also cover the year 1952 in the HCRC, start a new series of articles on satellites, report on the November and December meetings, and list all our new members! VHF Sweepstakes will get a thorough going over.

MERRY CHRISTMAS!!

DON'T FORGET THOSE WHO ARE LESS FORTUNATE THAN YOU ARE DURING THE HOLIDAYS.

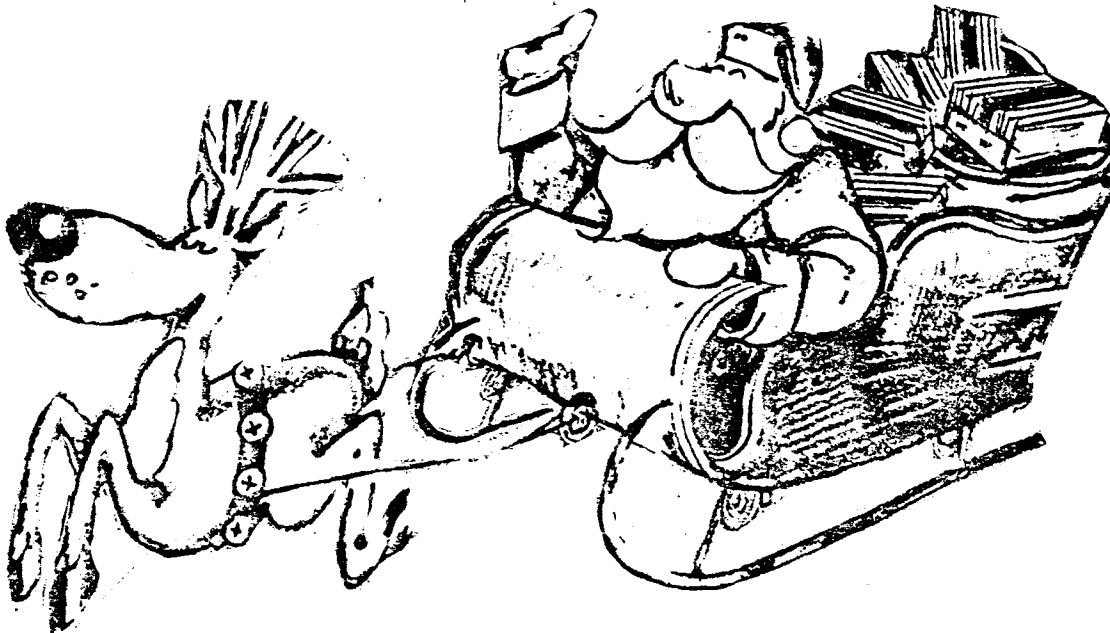

FIRST ANNUAL HAMPDEN COUNTY RA MOUNT TOM AMATEUR RA
CHRISTMAS PARTY!!!!

FRIDAY, DECEMBER 8th, 1978

Holyoke Lodge of Elk's #902
Whitney Avenue
Holyoke, Mass

COCKTAIL HOUR 6:30-7:30 pm

DINNER AT 7:30!

TICKETS: \$7.00 per person

DANCING TIL 1 am!

Tickets are available from:

Paul Lambert, WALURB
Don Johnson, WLUPH

WB1ETS, Ron Beauchemin
WB1FIP, Moe Beauchemin

KLYQQ, Chet Wisiolak
WB1CJH, Larry Soltz (567-3444)

WB1EMN, Al Sittard
WB1EHS, Barbara Murname

Jeff Duquette, K1BE

Frandy Johnson, N1FJ

After November 23rd, tickets can only be bought from:

Ron Beauchemin, WB1ETS
56 Acrebrook Drive
Chicopee, Mass 01020

SASE please.

NO Tickets sold after November 30th!
NONE, SOLD, AT THE DOOR!!!

Mount Tom Amateur Repeater Association

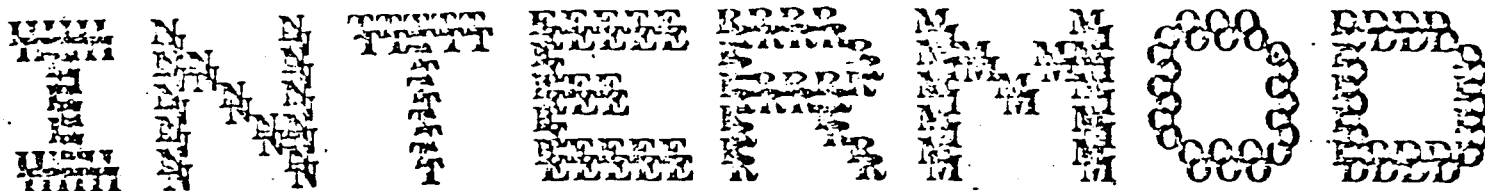

Volume VIII No. 7

WRLABX & WALURB/RPT

November 15 1978

JOINT ISSUE WITH ZERO-BEAT

THE FOX STRIKES AGAIN!

It was a sunny day on November 5. Everything was normal in area hamdom. Some were raking the last remaining leaves or painting a ceiling or two. Others were buried in cellars working the Sweepstakes, and some with not so much to do were listening to the chatter on WRLABX. Then suddenly, from nowhere - the fox and vixen struck. Using the bootleg call WALKGR, they challenged to be sought by the hunters and their hounds. There, listen to the vixen:

"Here we are, the Mt. Tom Fox.
Out in the clear upon some rocks.
Where to find us no one knows.
Keep on coming, just follow your nose.
Turn your antennas round and round.
Just don't point them to the ground.
We're sitting here drinking your beer.
When you find us, we'll be in good cheer."

Twelve hunters met at the Eastfield Mall with loops, a cubical quad, 19 inch whips, rubber duckies and a full sized rotatable 5 element yagi mounted on car rooves. "We're going to get you, fox", they said.

And so they did. It took some time, though. WLUPH and WLUXW did it in about an hour (and 12 miles) to win the event. Don and Cliff had taken two fixes and were taking a shortcut to a third hill top and practically ran over the fox and vixen on their way. An hour later (31 miles), NLAGV and NLAHW arrived with their 5 element yagi. Shortly thereafter, came WALCTQ and WB1DMF (36 miles). A half hour later, K1QIZ and WALZUH arrived on the scene with their "secret weapon", a 2-element cubical quad waving in the air. Their mileage was only 21 miles because, as they claimed, they walked a lot and also spent much of their travels in reverse. Craig, WALWZY, having taken a fix with his beam in Chicopee, arrived next. Finally, Paul and Bernice WALURB and WB1DHA joined the party. They wore out one car and had to come up in a second vehicle, mileage unknown. Phil, WB1AIM, arrived just under the wire and checked in with the record - 55 miles!

The fox and vixen, W1JP and WB1ABF, were finally caught, and shared a cache of cold 807's with the happy group.

The next hunt will be held early in December. It's like an Easter egg hunt. Something the whole family would enjoy. Won't you join us?

DO'S & DON'TS FOR REPEATERS

DO'S DO KEEP ALL TRANSMISSIONS SHORT. Emergencies don't wait for monologues to be finished. If you talk to hear your own voice what you want is a tape recorder, not an fm rig.

DO THINK BEFORE YOU TRANSMIT. If you can't think of anything worth saying, don't say anything.

DO PAUSE A COUPLE OF SECONDS BETWEEN EXCHANGES. Someone with a high-priority need for the repeaters are configured so that a brief pause in transmissions is necessary to reset the three-minute timer.

DO IDENTIFY PROPERLY. You must give your call at the beginning of a contact and every 10 minutes thereafter. At the end of the contact you must also give the call of the station with whom you were in contact.

DO BE COURTEOUS. A repeater is like a telephone party line, and requires the same kind of cooperation in its use.

DO USE SIMPLEX WHENEVER POSSIBLE. Leave the repeaters available for those who need them.

DO USE THE MINIMUM POWER NECESSARY to maintain communication. Not only is this an FCC requirement, it's common courtesy.

DO YOU SUPPORT YOUR LOCAL REPEATER CLUB even if it doesn't require all users to be members. Maintaining a good machine is an expensive undertaking, and you should do your share.

DON'TS DON'T ABUSE AUTOPATCH PRIVILEGES. Business messages are not permitted in the amateur service. Don't force the control operator to terminate your call in order to avoid a violation.

DON'T BREAK INTO A CONTACT unless you have something to add. Interrupting is no more polite on the air than it is in person.

DON'T FORGET THAT AMATEUR RADIO IS ALLOCATED FREQUENCIES BECAUSE IT IS A SERVICE not just a hobby. Don't neglect the public service aspects of Vhf-fm communication, such as accident reporting, emergency preparedness, etc.

DON'T TRY TO PROVE WHAT A GREAT OPERATOR YOU ARE by criticizing the operating techniques of others on the air. Instead, set an example which others will be proud to follow.

DON'T MONOPOLIZE A REPEATER. The best repeater users are the ones who do a lot of listening and little transmitting.

REMEMBER, WHAT YOU SAY OVER A REPEATER CAN BE HEARD OVER THOUSANDS OF SQUARE MILES by anyone with an inexpensive "public service band" monitor. These people are potential hams; if they like what they hear on the air, they will want to get licenses and join us. Don't leave them with a bad impression of our hobby by making thoughtless or off-color remarks.

THESE DO'S AND DON'TS ARE TAKEN FROM THE FM SCANNER AND ARRL.

10

SECRETARY SEZ: The following new members were voted in at the last regular meeting in September: WB1DLE, John Panek; WB1DOH, Sylvester Jamieson; WB1FZE, Thomas Lucchesi; W1GTU, Jeff Murray; and W1MOK, Myles Brennan. We welcome them to the association....Members are reminded that the expiration date of their membership in the association is included in the mailing label attached to INTERMOD, so there should never be a question about when to pay the dues. So please take notice of this information, and act upon it when the time comes....You are all reminded that when stations check in to a net, they should not leave the net without asking net control station for permission to secure (leave the net). The MTARA Information Net of October 18th was a good example of improper procedure regarding this behavior on behalf of many stations....WB1EHS

DEAR TOM

Dear Tom: I read "Worried's" letter in the last issue of INTERMOD and I would really like to help, but what can I do? I have had my ham ticket for about 40 years and I recently became retired. I am not the technical type (you could call me an "appliance operator", if you like) and I don't understand transistors. I would like to help out the tech committee, but I would probably get in the way. So, how can I contribute? Restless.

Dear Restless: One of the best ways that you or any one else can help out is to participate in all of the club activities. Show up at the club meetings. If you don't care for the program, then sponsor one. Maybe you have a friend who is in the antenna business and can give us all some expert help. Call him up and ask him to give us a talk on the subject. Get involved in the fox hunt or be prepared to give beam headings to catch turkeys. How about operating for a few hours in the VHF contest, just to give your fellow club members a few points.

I guess that our message is that everyone can add to the life breath and heart beat of the MTARA by giving a little or a lot - it doesn't matter if at least it's something. Be a leader, a participant - not a follower.

Dear Tom: My comment on the article on "DX and squirrels" is that the author is a nut! Animal Lover.

Dear Lover: Agreed.

Dear Tom: Pursuant to KITF's article, what would happen if I squashed a bug? Guilty.

Dear Guilty: It would probably cause it to rain.

Dear Tom: I am relatively new to ham radio and still have a great deal to learn. Among the few things that I did learn is that the combination of a coil and capacitor will make a resonant circuit and can be used to construct an oscillator circuit. The same effect can be obtained using a crystal in place of the coil and capacitor. I do not understand, however, how the code practice oscillator shown in the attached schematic works. I did borrow an oscilloscope (which I do not really know how to use) and obtained the waveforms shown.

Perhaps one of the club's more technically skilled members would be willing to provide an explanation of the following:

1. Why does this circuit act like an oscillator if it does not have a resonant circuit?
2. How is the "sawtooth" waveform created?
3. What would be the effect of changing the values of R1 and C1?
(Unfortunately, the transistor "died" when I was taking measurements - the oscillator was running continuously and this was apparently too much for Q1.)
4. Why is the output a series of "spikes" rather than a "sawtooth"?

P.S. I would also like to get information for simple directional antennas to use with my hand-held, two meter rig to use for the fox hunts. Iwanta Learn.

Dear Iwanta: We would like to ask one of our more technically oriented members to solve your puzzle. Hope we get some info for you in time for the next issue of Intermod. How about it whiz kids? Send your solution in to P. O. Box 3494 or to W1JP directly, and help out our friend, Iwanta.

Workable fox hunt antennas include 2-3 element yagis, cubical quads and DF loops. All are described in the Handbook but must be scaled down to 147 MHz.

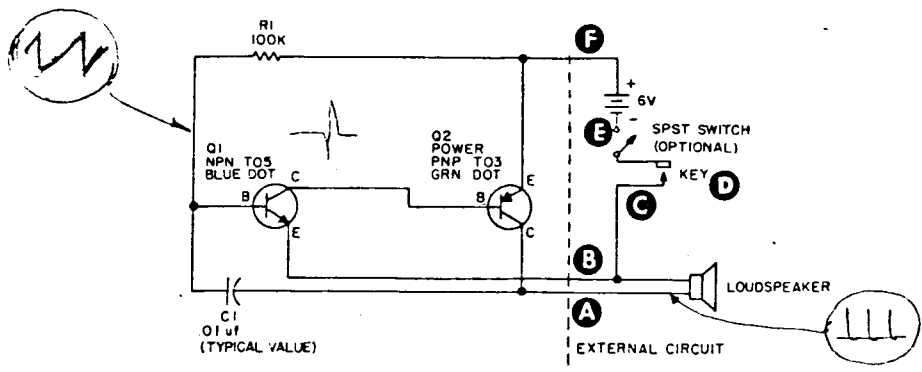

FOR SALE

- 1 - Harvey Wells Transmitter w/power supply - Model TB550F - \$35.00
- 1 - Heathkit "Twoer Transceiver" - \$25.00
- 1 - Hellicrafter S40A Receiver - \$40.00
- 1 - Hellicrafter SR150 Transceiver - \$300.00 - with matching AC and DC Power Supply
- 1 - Electronic Heathkit Keyer - \$60.00

WALDCH
 Rodolph E. Lambert
 95 Acker Circle
 Chicopee, Massachusetts, 01013
 1-413-592-2596

12
Mount Tom Amateur Repeater Association, Inc.

Intermod

COPYRIGHT 1978 By MOUNT TOM AMATEUR REPEATER ASSOCIATION, INC.

MOUNT TOM AMATEUR REPEATER ASSOCIATION, INC.

President: Don Johnson, WIUPH
Vice President: Robert A. Manning, K1CEX
Secretary: Barbara Murnane, WB1EHS
Treasurer: David W. Lloyd, W1PHU
Emergency Coordinator: W. Bing Leonard, K11QA
Asst. Emerg. Coordinator:

INTERMOD NEWSLETTER

Publisher:
Editor: William J. Hall, W1JP
Circulation: Robert Harvey, W1OJA
Composition & Paste-Up: Dave Lloyd, W1PHU
Label Maker: Tom Farrington, WA1SCO

WR1ABX — 146.34 In - 146.94 out
Mount Tom, Holyoke, Mass.
Trustee: John Bertini, K1ZJH
Technical Committee:
Paul A. Lambert, WA1URB
Thomas Wolos, WA1SCW

CLUB REPEATERS

WA1URB/RPT 146.40 In - 147.00 out
Agawam, Mass. (Autopatch)
Trustee: Paul A. Lambert, WA1URB
Technical Committee:
Robert A. Vander Vliet, WA1QWS
Philip George, WB1AIM

MOUNT TOM AMATEUR REPEATER ASS'N, INC.
POST OFFICE BOX 3494
SPRINGFIELD, MASSACHUSETTS, 01101



FIRST CLASS MAIL

AC1T
[REDACTED]

09/79