

NV1Q Opto-Keayer

TITLE

Zusammenbauzeichnung 1

SCALE

1:1

REV

1

DATE

2019-10-05

SHEET

1 of 7

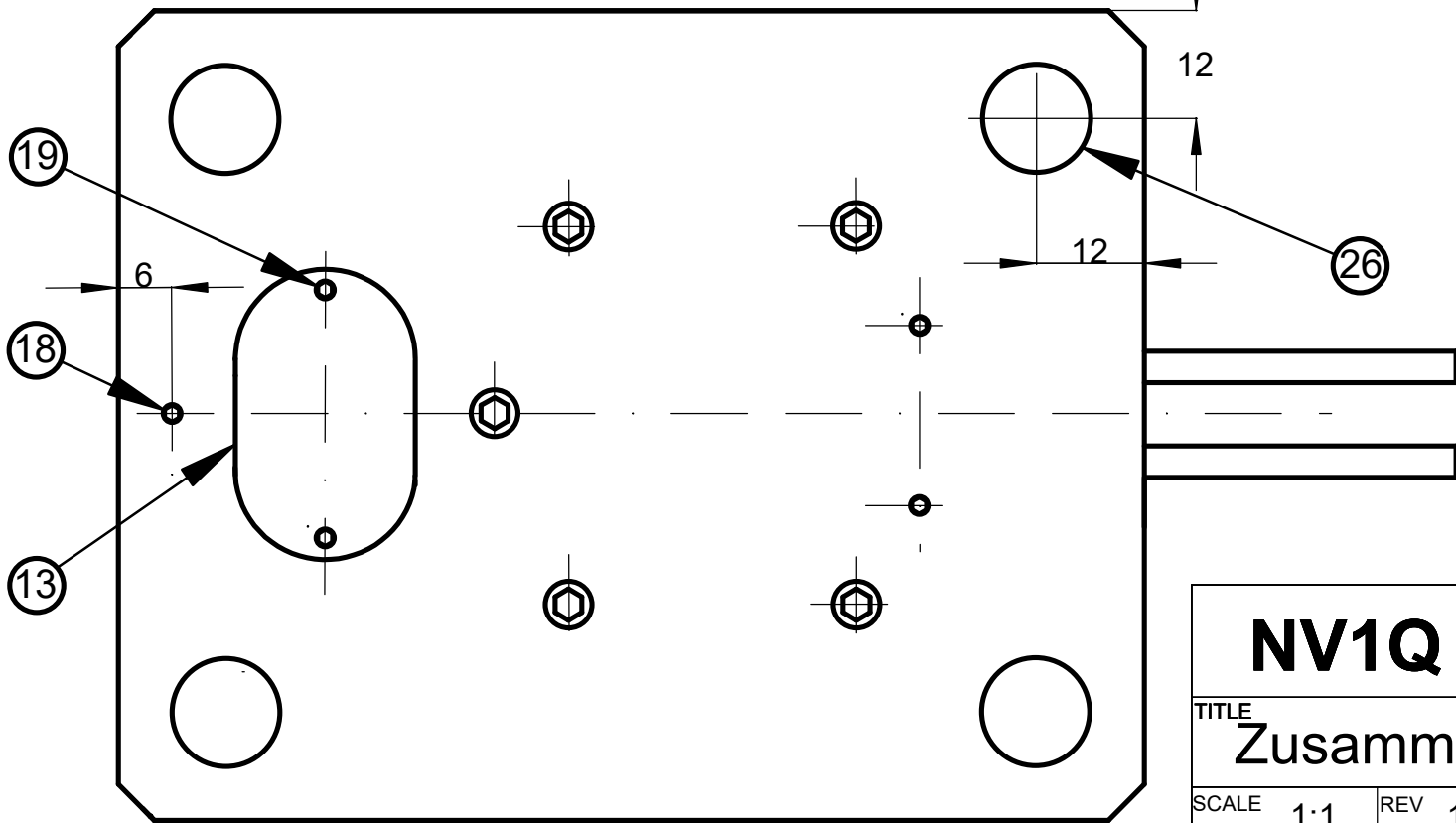
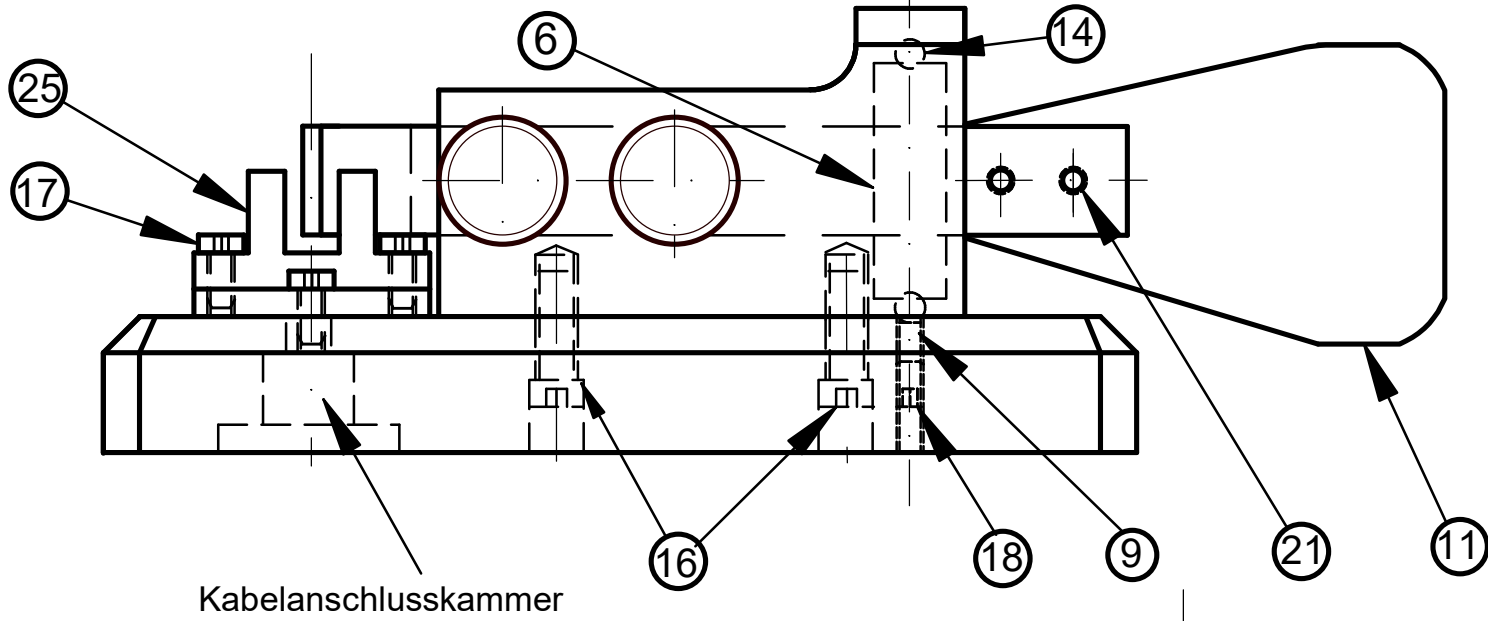

NV1Q Opto-Keayer			
TITLE Zusammenbauzeichnung 2			
SCALE	1:1	REV	1
DATE	2019-10-05	SHEET	2 of 7

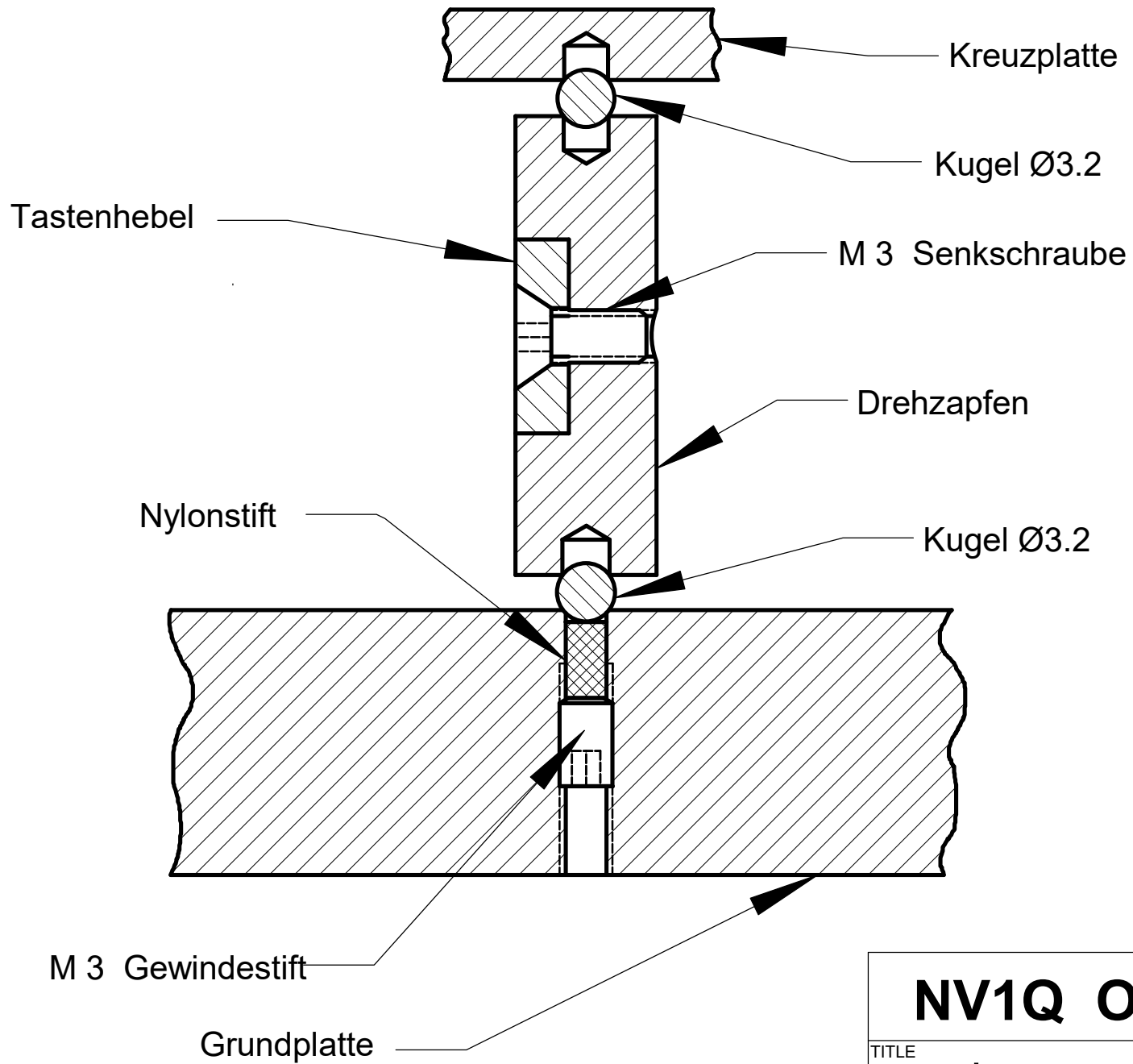

NV1Q Opto-Keayer

TITLE

Lagerung A-A

SCALE

3:1

REV

1

DATE

2019-10-05

SHEET

3 of 7

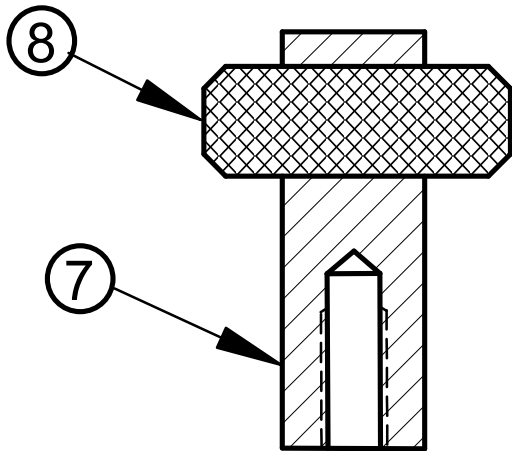

Teil 8 in Teil 7 gepresst

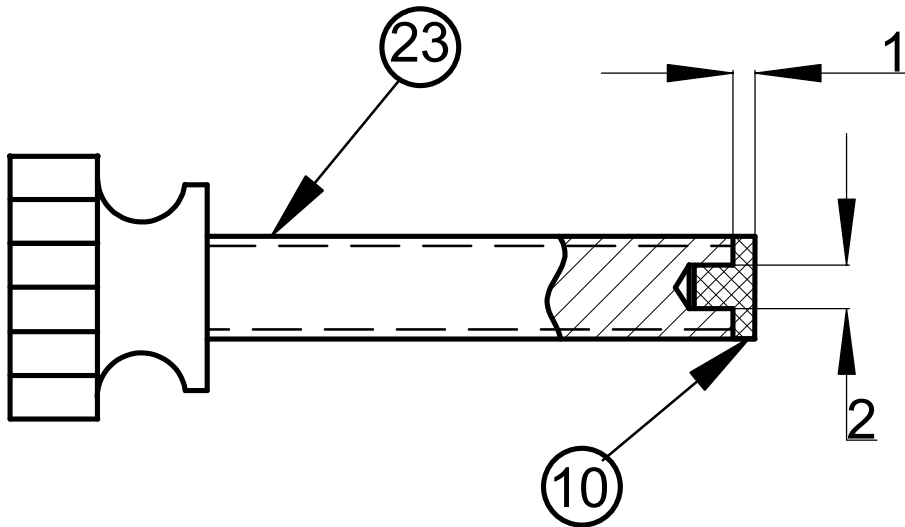

Teil 10 in Teil 23 gepresst

NV1Q Opto-Keyer

TITLE

Nylon-Anschlag

SCALE

3:1

REV

1

DATE

2019-10-05

SHEET

4 of 7

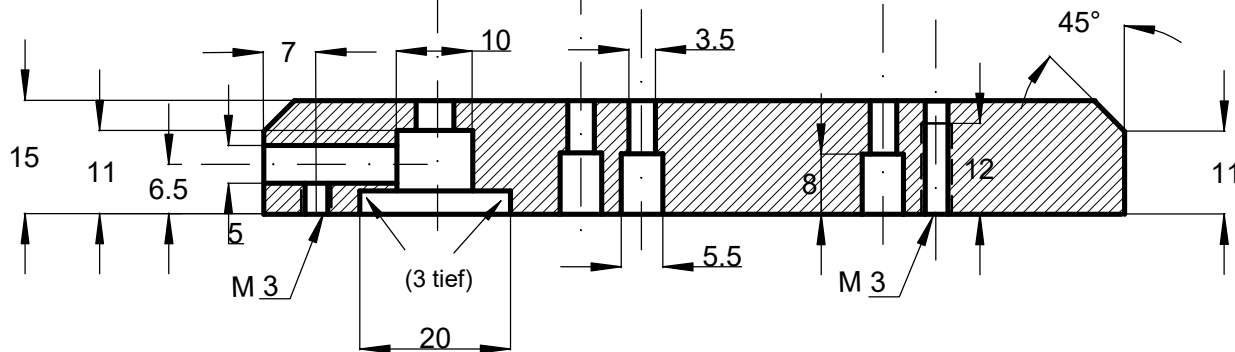
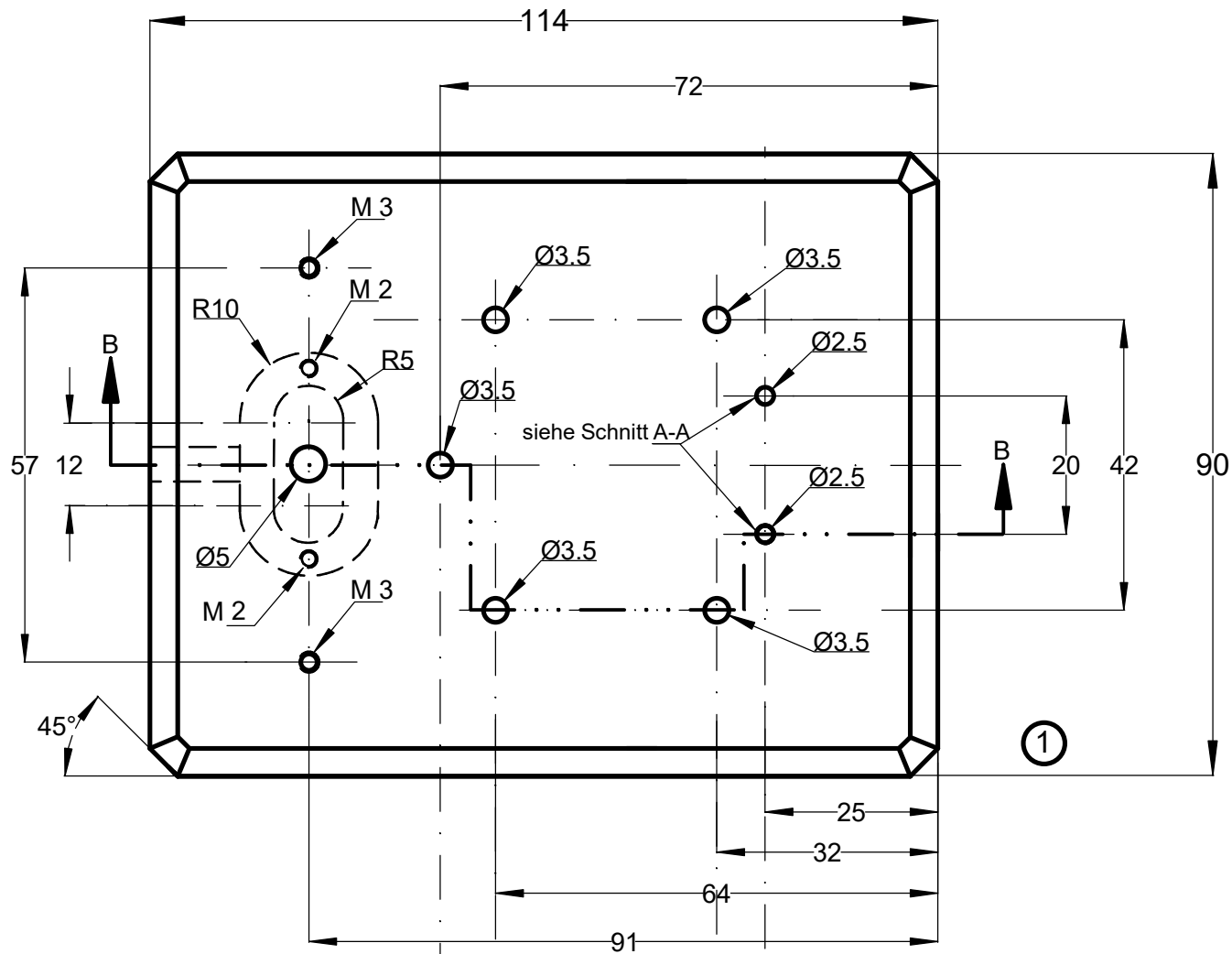

NV1Q Opto-Keyer

TITLE Grundplatte

SCALE 1:1 REV 1 DATE 2019-10-05 SHEET 5 of 7

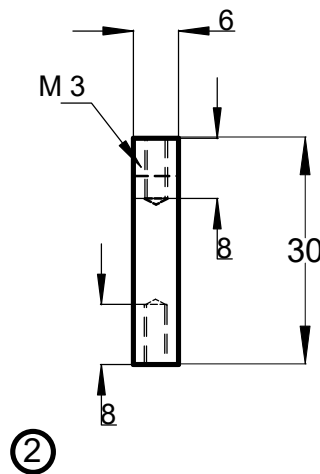
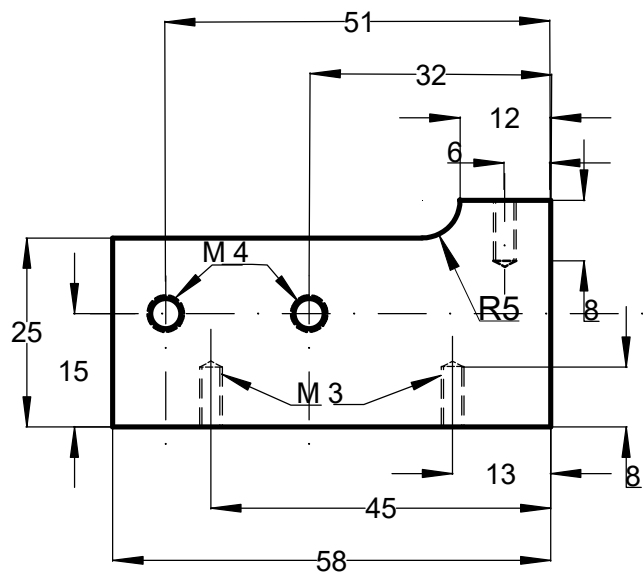
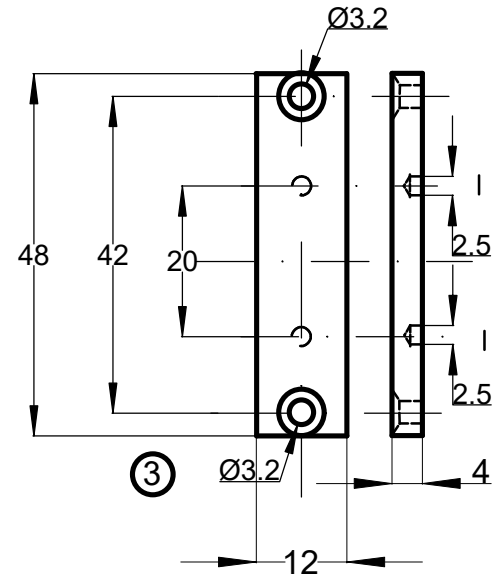
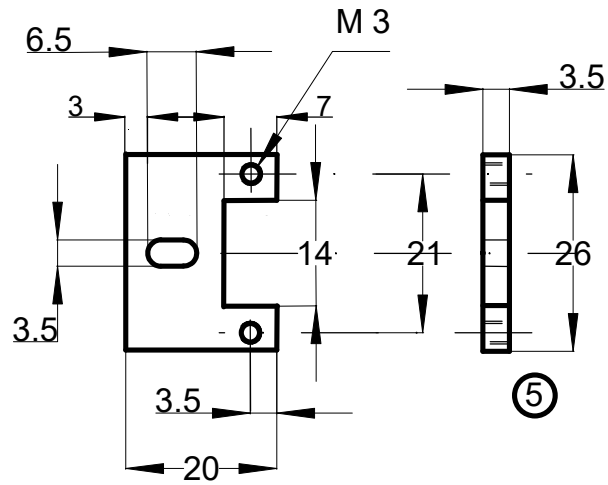

Pos.	Name	Anz.
2	Seitenteil	2
3	Kreuzplatte	1
4	Tastenhebel	2
5	Gleitplatte	2

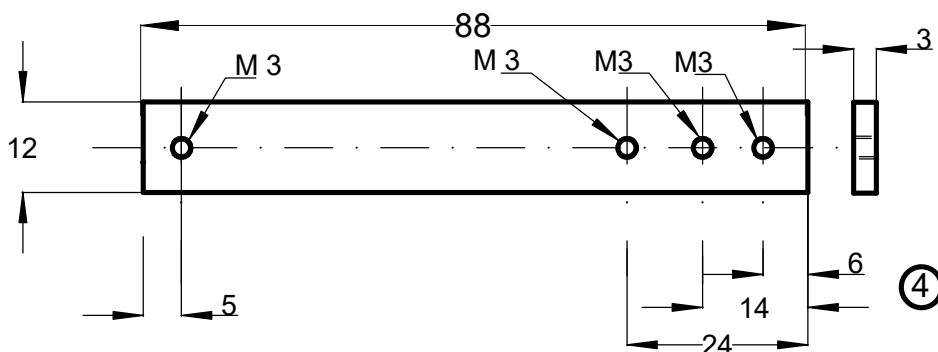

NV1Q Opto-Keyer

TITLE			
Fertigungsteile 1			
SCALE	1:1	REV	1
DATE	2019-10-05	SHEET	6 of 7

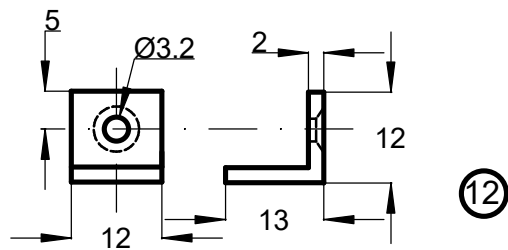
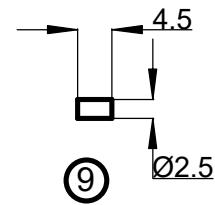
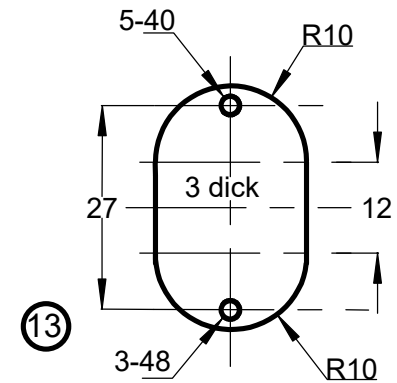
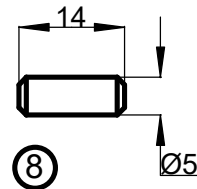
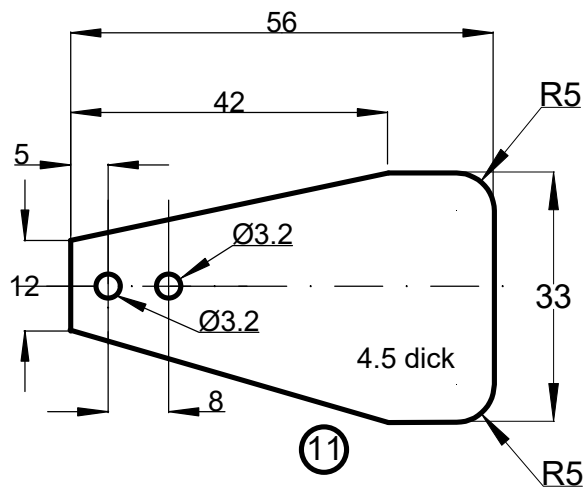
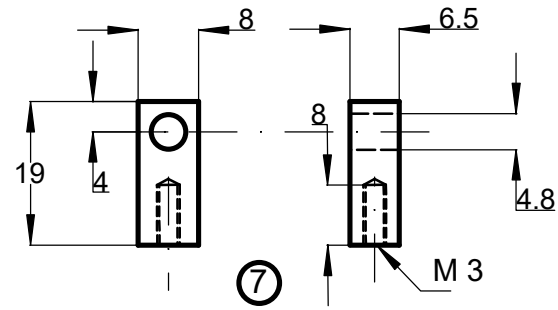
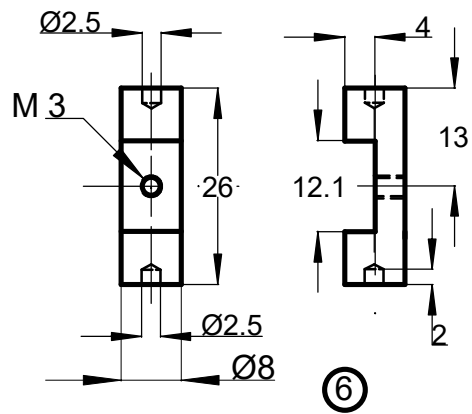

Pos.	Name	Anz.
6	Drehzapfen	2
7	Anschlagblock	1
8	Anschlagstift	2
9	Endanschlag	2
11	Paddle	2
12	Fahne	2
13	Deckplatte	1

NV1Q Opto-Keyer

TITLE

Fertigungsteile 2

SCALE 1:1

REV 1

DATE 2019-10-05

SHEET 7 of 7

NV1Q Opto-Keyer – Stückliste

Position	Bezeichnung	Menge	Norm / Werkstoff
1	Grundplatte	1	Bronze
2	Seitenteil	2	Bronze
3	Kreuzplatte	1	Bronze
4	Tastenhebel	2	Bronze
5	Gleitplatte	2	Bronze
6	Drehzapfen	2	Bronze
7	Anschlagblock	1	Bronze
8	Anschlagstift	1	Nylon
9	Endanschlag	2	Nylon
10	Schraubenanschlag	2	Nylon
11	Paddel	2	Acrylic
12	Fahne	2	Hartvinyl
13	Deckplatte	1	Bronze
14	Kugel	4	Edelstahl
15	Spiralfeder	2	Federstahl
16	Zylinderschraube M 3 X 16	6	DIN 912
17	Zylinderschraube M 3 X 6	4	DIN 912
18	Gewindestift M 3 X 6	3	DIN 913
19	Gewindestift M 2 X 6	2	DIN 913
20	Senkschraube M 3 X 6	6	DIN 7991
21	Linsenschraube M 3 X 6	4	DIN 85
22	Rändelschraube M 4 X 18	2	Messing
23	Rändelschraube M 4 X 24	2	Messing
24	Rändelmutter M 4	4	Messing
25	Gabellichtschränke	2	
26	Türstopper	4	Gummi

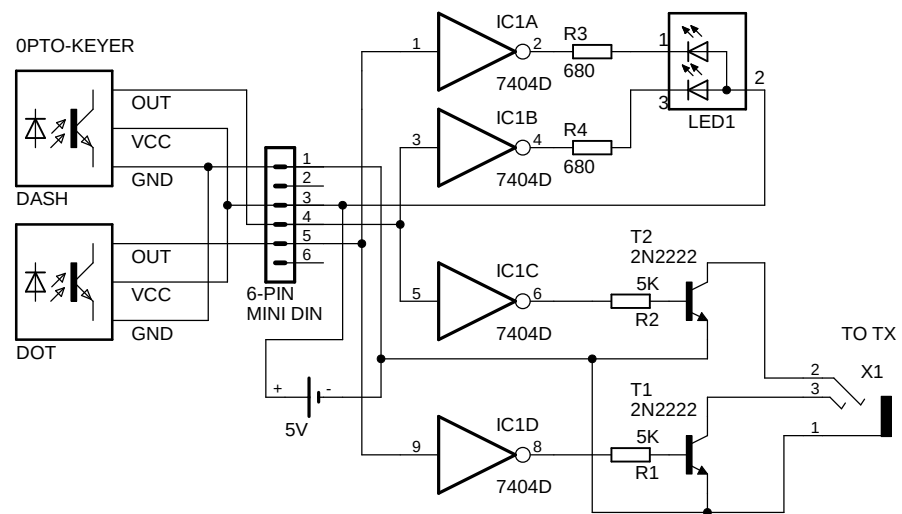

TITLE: NV1Q - Opto Keyer

Document Number:

REV:

Date: 2019-03-25 15:55

Sheet: 1/1